

SIEMENS

SIMATIC

Industrial PC SIMATIC IPC347G

Operating Instructions

Preface

Product description

1

Safety instructions

2

Installing and connecting
the device

3

Commissioning the device

4

Operating the device

5

Expanding and assigning
parameters to the device

6

Device maintenance and
repair

7

Technical specifications

8

Dimension drawings

9

Standards and approvals

10

BIOS description

11

Hardware description

A

Technical support

B

Markings and symbols

C



List of abbreviations

D

Legal information

Warning notice system

This manual contains notices you have to observe in order to ensure your personal safety, as well as to prevent damage to property. The notices referring to your personal safety are highlighted in the manual by a safety alert symbol, notices referring only to property damage have no safety alert symbol. These notices shown below are graded according to the degree of danger.

 DANGER
indicates that death or severe personal injury will result if proper precautions are not taken.
 WARNING
indicates that death or severe personal injury may result if proper precautions are not taken.
 CAUTION
indicates that minor personal injury can result if proper precautions are not taken.
NOTICE
indicates that property damage can result if proper precautions are not taken.

If more than one degree of danger is present, the warning notice representing the highest degree of danger will be used. A notice warning of injury to persons with a safety alert symbol may also include a warning relating to property damage.

Qualified Personnel

The product/system described in this documentation may be operated only by **personnel qualified** for the specific task in accordance with the relevant documentation, in particular its warning notices and safety instructions. Qualified personnel are those who, based on their training and experience, are capable of identifying risks and avoiding potential hazards when working with these products/systems.

Proper use of Siemens products

Note the following:

 WARNING
Siemens products may only be used for the applications described in the catalog and in the relevant technical documentation. If products and components from other manufacturers are used, these must be recommended or approved by Siemens. Proper transport, storage, installation, assembly, commissioning, operation and maintenance are required to ensure that the products operate safely and without any problems. The permissible ambient conditions must be complied with. The information in the relevant documentation must be observed.

Trademarks

All names identified by ® are registered trademarks of Siemens AG. The remaining trademarks in this publication may be trademarks whose use by third parties for their own purposes could violate the rights of the owner.

Disclaimer of Liability

We have reviewed the contents of this publication to ensure consistency with the hardware and software described. Since variance cannot be precluded entirely, we cannot guarantee full consistency. However, the information in this publication is reviewed regularly and any necessary corrections are included in subsequent editions.

Preface

Purpose of the operating instructions

These operating instructions contain all the information you need for the installation, electrical connection, commissioning, expansion of the SIMATIC IPC347G and to maintain and repair the device. They are intended for the following qualified specialist personnel:

- Installation personnel
- Commissioning engineers
- IT administrators
- Service and maintenance personnel

Basic knowledge required

A solid background in electrical installation, personal computers, Microsoft operating systems and network technology is required to understand this manual. General knowledge in the field automation control engineering is recommended.

Range of validity of these operating instructions

These operating instructions are valid for all supplied versions of the SIMATIC IPC347G.

History

Currently released versions of these operating instructions:

Edition	Comment
10/2020	First edition

Table of contents

	Preface	3
1	Product description	8
1.1	Important instructions and manuals for operating the device	8
1.2	Product highlights	9
1.3	Scope of application	10
1.4	External design of the device	11
1.4.1	Front panel.....	11
1.4.2	Rear of the device	12
1.4.3	Drive cage	13
1.4.4	Interfaces and connections	14
1.4.4.1	Interfaces	14
1.4.4.2	Power supply connections.....	15
1.4.5	Operator controls	15
1.4.6	Status displays.....	17
1.4.6.1	System status displays	17
1.4.6.2	Status display of the Ethernet interface	17
1.5	Internal construction of the device.....	18
2	Safety instructions	19
2.1	Security information	19
2.2	General safety instructions.....	19
2.3	Disclaimer for third-party software updates.....	21
2.4	Data protection.....	21
2.5	Note on transport and storage	22
2.6	Notes on mounting.....	23
2.7	Notes on ambient and environmental conditions	24
2.8	Information on I/O devices	25
2.9	Notes on device and system extensions.....	26
3	Installing and connecting the device	28
3.1	Preparing for mounting.....	28
3.1.1	Scope of delivery	28
3.1.2	Checking the delivery package.....	29
3.1.3	Device identification data	29
3.2	Mounting the device.....	31
3.2.1	Mounting types	31
3.2.2	Securing device	32
3.3	Connecting the device	34

3.3.1	Country-specific information on supply voltage	34
3.3.2	Connecting the function earth	35
3.3.3	Connecting the power supply.....	36
3.3.4	Connecting I/O devices.....	37
3.3.5	Connecting device to networks	38
3.3.6	Dual-monitoring	38
4	Commissioning the device	39
4.1	Initial commissioning.....	39
4.2	Switching off the device.....	40
5	Operating the device	42
5.1	Opening the front door	42
5.2	Monitoring functions	43
6	Expanding and assigning parameters to the device	44
6.1	Open the device	44
6.2	Expansion cards.....	46
6.2.1	Usable expansion cards.....	46
6.2.2	Installing expansion cards	46
6.3	Memory modules.....	48
6.3.1	Usable memory modules.....	48
6.3.2	Installing memory modules.....	49
6.4	Drives (HDD/SSD)	50
6.4.1	Installation options for drive	50
6.4.2	Removing the drive module	51
6.4.3	Installing the drive (HDD/SSD)	52
6.4.4	Removing and installing internal HDD/SSD	54
7	Device maintenance and repair.....	55
7.1	Repair information	55
7.2	Maintenance intervals.....	55
7.3	Removing and installing hardware	56
7.3.1	Replacing the filter.....	56
7.3.2	Replacing the device fan	57
7.3.3	Changing the backup battery	58
7.3.4	Changing the power supply	60
7.3.5	Replacing the processor	62
7.3.6	Replacing the motherboard.....	64
7.4	Installing operating system, software and drivers	65
7.4.1	Installing software and drivers	65
7.5	Recycling and disposal	68
7.6	Beep code.....	68
8	Technical specifications.....	69
8.1	Applicability of technical specifications.....	69
8.2	General technical specifications	69

8.3	Current/power requirements and power supply.....	70
8.3.1	Power requirements of the components (maximum values)	70
8.3.2	Technical specifications of basic power supply	71
8.4	Electromagnetic compatibility.....	71
8.5	Ambient conditions	72
8.6	Technical specifications of the drives.....	73
8.7	Technical specifications of the motherboard.....	73
8.8	Technical specifications of graphic	74
8.9	Technical specifications of the interfaces.....	74
8.10	Technical specifications of the telescopic rails	75
8.11	Technical specifications of the operating systems.....	75
8.12	Directives and declarations	75
8.12.1	Electromagnetic compatibility, Industrial and Residential Areas	75
8.12.2	ESD guideline	76
9	Dimension drawings.....	78
9.1	Dimension drawing of the expansion cards	79
9.2	Dimension drawing of the telescope rails	79
10	Standards and approvals	80
11	BIOS description	83
11.1	BIOS getting started.....	83
11.2	Main menu	85
11.3	Advanced menu.....	86
11.4	Hardware Monitor menu.....	93
11.5	Boot menu	94
11.6	Security menu	96
11.7	Save & Exit menu.....	99
A	Hardware description	100
A.1	Motherboard	100
A.1.1	Layout of the motherboard	100
A.1.2	Position of the interfaces on the motherboard.....	101
A.1.3	Jumpers	102
A.2	External interfaces	104
A.2.1	USB 3.0 port	105
A.2.2	USB 2.0 port	105
A.2.3	Serial interface	106
A.2.4	Ethernet	107
A.2.5	DisplayPort	107
A.3	Internal Connector.....	108
A.3.1	Fan connector	108
A.3.2	Front panel connector (F_Panel1 & F_Panel2).....	109

A.3.3	Internal USB 2.0 connector (USB56 & USB78)	109
A.3.4	Internal RS232 COM Connector (COM3 & COM4)	110
A.3.5	Internal USB 2.0 Vertical Connector (USB9 & USB10)	110
A.3.6	Internal TPM 14-pin connector	111
A.3.7	ATX power 24-pin connector (EATX_PWR1)	111
A.3.8	ATX Power 4-pin connector (EATX_PWR2)	112
A.3.9	M.2 B Key slot.....	112
A.3.10	Intel CPU socket (LGA1151)	112
A.3.11	DDR4 Memory sockets (DIMM_A1 & DIMM_B1)	113
A.3.12	SATA 6.0 Gbps Port Connectors (SATA6G_1/ SATA6G_2/ SATA6G_3).....	113
A.3.13	Battery socket.....	113
B	Technical support	114
B.1	Service and support	114
B.2	Troubleshooting	115
B.2.1	Problems with device functions.....	115
B.2.2	Problems when booting the device	116
B.2.3	Problems when using expansion cards	117
C	Markings and symbols.....	118
C.1	Overview	118
C.2	Safety.....	118
C.3	Operator controls.....	118
C.4	Certificates, approvals and markings	119
C.5	Interfaces	120
D	List of abbreviations	121
	Index.....	123

Product description

1.1 Important instructions and manuals for operating the device

Documentation	Contents	Source
Operating instructions	<ul style="list-style-type: none"> • Product description • Technical specifications • Installation of the device • Operation of the device • Installing and removing hardware • Dimension drawings 	<ul style="list-style-type: none"> • Supplied data storage medium • Online at: SIMATIC IPC Documentation (http://www.siemens.com/simatic-ipc-doku-portal)
Quick Install Guide	Information on: <ul style="list-style-type: none"> • Operating Instructions of the device • Installation of the device • Steps for connecting the device to the power supply • Connecting I/O devices • Switching the device on 	<ul style="list-style-type: none"> • Supplied in printed form with the device • Supplied data storage medium
Current product information	<ul style="list-style-type: none"> • Current notes on the device • Changes compared with these operating instructions 	<ul style="list-style-type: none"> • Online at: SIMATIC IPC Documentation (http://www.siemens.com/simatic-ipc-doku-portal)
Windows® operating system	Information on: <ul style="list-style-type: none"> • Commissioning the operating system • Restoring the operating system • Configuration of the operating system 	<ul style="list-style-type: none"> • Supplied data storage medium • Online at: Microsoft® Windows® 10 (https://support.industry.siemens.com/cs/ww/en/view/109749498)

1.2 Product highlights

The SIMATIC IPC347G is an industrial PC in 19" rack format design (4U). It is perfectly suited for PC applications with high-level industry functionality.

- Powerful processors up to Intel Core i7 (6th generation)
- No additional dust protection measures required thanks to filter mat and overpressure ventilation
- Robust all-metal enclosure
- Variety of interfaces
- Lockable front cover
- Prepared for mounting on telescopic rails



Note

The supplied device may differ in some details from the figures contained in this manual. Within some of the figures, one device is used to represent all devices.

SIMATIC IPC347G configuration plan

Type	<ul style="list-style-type: none">• 19" rack, 4 U
Mounting	<ul style="list-style-type: none">• Support horizontal installation
Chipset	<ul style="list-style-type: none">• Intel® H110
CPU type	<ul style="list-style-type: none">• Intel® Pentium® Processor G4400 (2C/2T; 3M Cache, 3.30 GHz)• Intel® Core™ i5-6500 Processor (4C/4T; 6M Cache, up to 3.60 GHz)• Intel® Core™ i7-6700 Processor (4C/48; 8M Cache, up to 4.00 GHz)
Memory	<ul style="list-style-type: none">• 4 GB DDR4-2133• 8 GB DDR4-2133• 16 GB DDR4-2133• 2 * 16 GB DDR4-2133
Drive bays	<ul style="list-style-type: none">• 1 × 3.5" slot• 3 × 5.25" slot
Hard Disk Drive (HDD)	<ul style="list-style-type: none">• 1 TB HDD

1.3 Scope of application

Solid State Drive (SSD)	<ul style="list-style-type: none">• 256 GB SSD• 512 GB SSD
Power Supply	<ul style="list-style-type: none">• 350W
Operation System	<ul style="list-style-type: none">• Windows 10 Enterprise 2019 LTSC (Long Term Servicing Channel) 64-bit (MUI)• Without

- ¹ MUI: Multi-language user interface; More language packages are available on the USB stick. You can install them according to your request.

1.3 Scope of application

The SIMATIC IPC offers system integrators, cabinet designers, system engineers and machine designers a 19" rack PC platform for high-performance applications and IT applications on the control and cell level for:

- Process and visualization applications
- Industrial image processing
- Quality assurance and monitoring tasks
- Measurement, control and rule-based tasks
- Data acquisition and management

The SIMATIC IPC has CE certification for use in the industrial sector as well as in residential and commercial areas and small businesses. In addition to the industrial applications, therefore, it can also be used in building automation or in public facilities.

1.4 External design of the device

1.4.1 Front panel

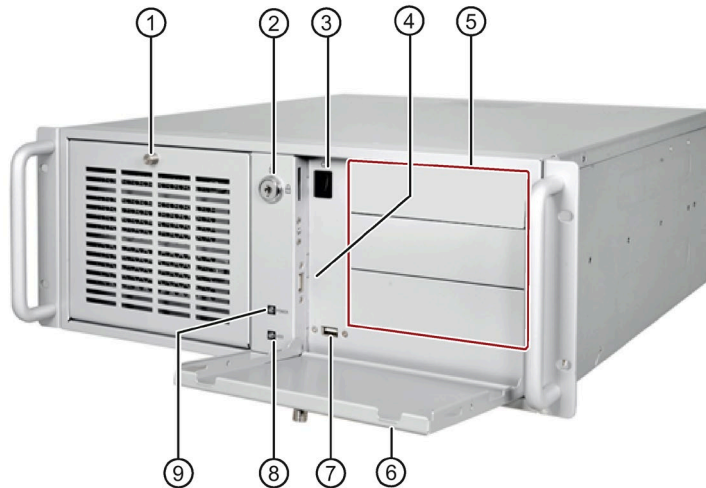

- | | |
|--|---|
| ① Front left door | ⑥ Front right door |
| ② Lock | ⑦ Connections for USB 2.0 devices,
compatible with USB 1.1 |
| ③ On/off button | ⑧ HDD status display |
| ④ Connection for USB 2.0 devices,
compatible with USB 1.1 | ⑨ Power status display |
| ⑤ Drive bays 3 x 5.25" | |

1.4.2 Rear of the device

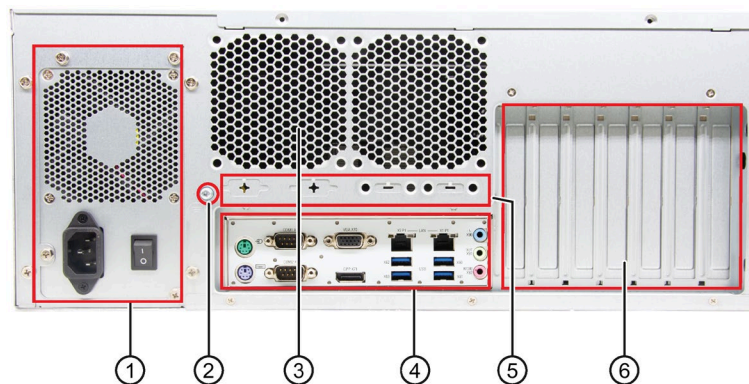

- ① Power supply
 - ② Function earth
 - ③ Air outlet
 - ④ Interfaces
 - ⑤ Extensible interface
 - ⑥ Expansion slots for:
 - 3 × PCI
 - 3 × PCIe x4*; Gen 2.0
 - 1 × PCIe x16; Gen 3.0
- * Open direct plug sockets

1.4.3 Drive cage

The drive cage is located behind the front door.

In drive cage, drives are permanently installed inside and cannot be accessed externally.

The drives are very well protected against vibration and oscillation ("vibration-damped drive cage") in this drive cage.



Drive bays

①	Mounting location 1	Mounting location for 3.5" or 2.5" drive in a shock-proof/vibration-proof fixture or for 5.25" drive or components
②	Mounting location 2	Mounting location for 3.5" or 2.5" drive in a shock-proof/vibration-proof fixture or for 5.25" drive or components
③	Mounting location 3	Mounting location for 3.5" or 2.5" drive in a shock-proof/vibration-proof fixture or for 5.25" drive or components

Components

(A)	Cover
(B)	Front right door

Additional information

Technical notes and information on the rated conditions are available in the section Installation options for drive (Page 50).

1.4.4 Interfaces and connections

1.4.4.1 Interfaces

Note

You can find the detailed information on interfaces under "External interfaces (Page 104)".

Interfaces at rear of device

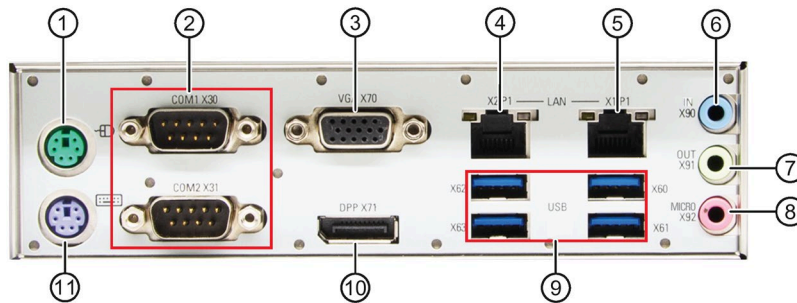

- | | | |
|---|------------------------|--|
| ① | Mouse port | Connection for a PS/2 mouse |
| ② | COM1 X30
COM2 X31 | Serial interface, 9-pin RS232 /RS422 /RS485 |
| ③ | VGA X70 | Connection for monitor with Video Graphics Adapter (VGA) interface |
| ④ | LAN2 ¹ X2P1 | RJ-45 Ethernet Port for 10/100/1000Mbps LAN, the MAC-Address is listed in Component label. |
| ⑤ | LAN1 ¹ X1P1 | RJ-45 Ethernet Port for 10/100/1000Mbps LAN, the MAC-Address is listed in Component label. |
| ⑥ | Line in (blue) | Connection for analog audio source, 3.5 mm phono jack |
| ⑦ | Line out (green) | Connection for active speakers or headset, 3.5 mm phono jack |
| ⑧ | Microphone (pink) | Connection for microphone, 3.5 mm phono jack |
| ⑨ | USB 3.0 ² | Connections for USB devices, compatible with USB 2.0/1.1 |
| ⑩ | DP port X71 | Connection of a digital monitor ³ |
| ⑪ | Keyboard port | Connection for a PS/2 keyboard |

¹ See the pin assignment below.

² Each of the USB port can be disabled/enabled separately by disabling/enabling its associated USB port in BIOS. On how to disable the USB port, see USB configuration in Advanced menu (Page 86).

³ Use the DP cable of which the length is less than 15 meters, and the DP cable must comply with VESA DisplayPort standard.

1.4.4.2 Power supply connections

The following figure shows the power supply connector.



1.4.5 Operator controls

⚠ WARNING

Risk of electric shock

The buttons and switches described in the following do not fully disconnect the device from the line voltage.

You also need to the notes and information under "Switching off the device (Page 40)".

On/Off switch

The following figure shows the location of the on/off switch.



① On/Off switch

On/Off button

Note

The on/off button is only effective when the power supply is switched on via the on/off switch at the rear of the device.

Note

The PC switches on automatically after the power recovers when "Restore AC Power Loss" is active.

Depending on the "Restore AC Power Loss" setting in BIOS, the PC switches on automatically or you must press the on/off button on the front. The BIOS setting only becomes effective when the device is without mains voltage for at least 10 seconds.

Automatic startup may endanger the operation of the machine or plant, for example, after a power failure. Take this into account when designing the plant.

The following figure shows the position of the on/off button at the front of the device.



The on/off button ① has three functions:

- Switch on the PC, press the on/off button once shortly.
- Shut down the operating system and switch off PC, press the on/off button once shortly.¹
- Switch off PC without shutting down the operating system, press for more than 4 seconds – hardware reset.

¹ You can set this operation as shut down or hibernate in operating system.

NOTICE

Data loss

If the device is restarted by hardware reset, data in the main memory is deleted and the data on the hard disk drive may be lost.

Perform a hardware reset only in the case of an emergency. Close all running programs. Make sure that there is no more read or write access to drives and I/O before performing the hardware reset.

1.4.6 Status displays

1.4.6.1 System status displays

The status displays for the system are located on the front of the device. They provide information on the status of the device components.



Item	Status display	Meaning	LED	Description
①	POWER	Operating mode of the PC	Off	Hibernate, switched off or unplugged
			Green	PC in operation
②	HDD	Display for hard disk access	Off	No accessing
			Green flashing	Accessing data

1.4.6.2 Status display of the Ethernet interface

The Ethernet interfaces are numbered on the enclosure to identify them clearly. The numbering by the operating system can differ.

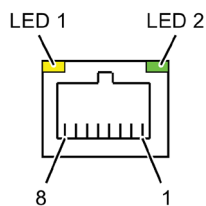

Status display	Meaning	Status	Meaning of the status
LED 1	Connection status	OFF	<ul style="list-style-type: none"> No cable connected Physical link disconnects Interface disabled
		Yellow	<ul style="list-style-type: none"> Active connected
		Yellow flashing	<ul style="list-style-type: none"> Data transfer active
LED 2	Data transmission rate	OFF	<ul style="list-style-type: none"> 10 Mbps
		Orange	<ul style="list-style-type: none"> 100 Mbps
		Green	<ul style="list-style-type: none"> 1000 Mbps

1.5 Internal construction of the device

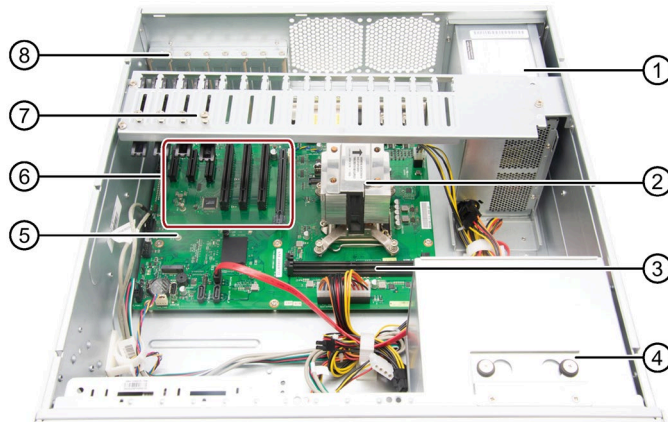

- ① Power supply
- ② Heat sink of the processor
- ③ Motherboard with slots for memory slots
- ④ Drive cage
- ⑤ Motherboard
- ⑥ Slots for expansion cards
- ⑦ Card holder for expansion cards
- ⑧ On the enclosure: Numbering of slots for expansion cards

Safety instructions

2.1 Security information

Siemens provides products and solutions with industrial security functions that support the secure operation of plants, systems, machines and networks.

In order to protect plants, systems, machines and networks against cyber threats, it is necessary to implement – and continuously maintain – a holistic, state-of-the-art industrial security concept. Siemens' products and solutions constitute one element of such a concept.

Customers are responsible for preventing unauthorized access to their plants, systems, machines and networks. Such systems, machines and components should only be connected to an enterprise network or the internet if and to the extent such a connection is necessary and only when appropriate security measures (e.g. firewalls and/or network segmentation) are in place.

For additional information on industrial security measures that may be implemented, please visit (<https://www.siemens.com/industrialsecurity>).

Siemens' products and solutions undergo continuous development to make them more secure. Siemens strongly recommends that product updates are applied as soon as they are available and that the latest product versions are used. Use of product versions that are no longer supported, and failure to apply the latest updates may increase customers' exposure to cyber threats.

To stay informed about product updates, subscribe to the Siemens Industrial Security RSS Feed visit (<https://www.siemens.com/industrialsecurity>).

2.2 General safety instructions

 WARNING
The installer of the system is responsible for the safety of a system in which the device is integrated.
There is a risk of malfunction which could result in death or serious injury.
<ul style="list-style-type: none">• Ensure that only suitably qualified personnel perform the work.

Risk of physical injury

 **CAUTION**

Risk of physical injury

The device is heavy. When the device falls down, it can be damaged and personal injury may result.

- Use the handles on the front panel to carry and lift the device.

Risk due to electric shock

 **WARNING**

Risk of electric shock

The on/off button and on/off switch do not fully disconnect the device from the mains.

There is also a risk of fire if the device or connecting lines are damaged.

- Always fully disconnect the device from the mains voltage before performing work on the device or when the device will not be used over an extended period of time.
- For control cabinet mounting: Use a central, easily accessible AC circuit breaker close to the device, if possible.

Risk of lightning strikes

 **DANGER**

Risk of lightning strikes

A lightning flash may enter the mains cables and data transmission cables and jump to a person.

Death, serious injury and burns may result from the lightning strikes.

Death or serious bodily injury can result.

- Disconnect the device from the power supply in good time when a thunderstorm is approaching.
- Do not touch power cables and data transmission cables during a thunderstorm.
- Keep sufficient distance from electric cables, distributors and systems.

Avoiding functional restrictions

NOTICE

Possible functional restrictions in case of non-validated plant operation

The device is tested and certified on the basis of the technical standards. In rare cases, functional restrictions can occur during plant operation.

Validate the correct functioning of the plant to avoid functional restrictions.

ESD directive



Electrostatic sensitive devices can be labeled with an appropriate symbol.

NOTICE

Electrostatic sensitive devices (ESD)

The device contains electronic components that might be destroyed by electrostatic charges. This can result in malfunctions and damage to the machine or plant.

Take corresponding precaution measures before you open the device.

2.3 Disclaimer for third-party software updates

This product includes third-party software. Siemens AG only provides a warranty for updates/patches of the third-party software, if these have been distributed as part of a Siemens software update service contract or officially released by Siemens AG. Otherwise, updates/patches are undertaken at your own risk. You can find more information about our Software Update Service offer on the Internet at Software Update Service (<https://new.siemens.com/us/en.html>).

2.4 Data protection

Siemens observes the data protection guidelines, especially the requirements regarding data minimization (privacy by design). This means the following for this SIMATIC product: The product does not process / save any personal information, but only technical functional data (e.g. time stamps). If the user links this data to other data (e.g. shift plans) or if the user saves personal information on the same medium (e.g. hard disk) and therefore creates a personal reference in the process, the user has to ensure meeting the guidelines regarding data protection.

2.5 Note on transport and storage

Damage caused by transportation and storage

NOTICE
Damage to the device during transport and storage
<p>If a device is transported or stored without packaging, shocks, vibrations, pressure and moisture may impact the unprotected unit. Damaged packaging indicates that ambient conditions have already had a massive impact on the device and it may be damaged.</p> <p>This might cause the device, machine or plant to malfunction.</p> <ul style="list-style-type: none">• Keep the original packaging.• Pack the device in the original packaging for transportation and storage.

 WARNING
Electric shock and fire hazard due to damaged device
<p>A damaged device can be under hazardous voltage and trigger a fire in the machine or plant. A damaged device has unpredictable properties and states.</p> <p>Death or serious injury could occur.</p> <ul style="list-style-type: none">• Avoid installing and commissioning a damaged device.• Label the damaged device and keep it locked away. Send off the device for immediate repair.

Damage from condensation

NOTICE
Damage from condensation
<p>If the device is subjected to low temperatures or extreme fluctuations in temperature during transportation, moisture could occur on or inside the IPC device (condensation).</p> <p>Moisture can cause a short-circuit in electrical circuits and damage the device.</p> <ul style="list-style-type: none">• Store the device in a dry place.• Bring the device to room temperature before starting it up.• Do not expose the device to direct heat radiation from a heating device.• If condensation develops, wait approximately 12 hours or until the device is completely dry before switching it on.

2.6 Notes on mounting

Enclosure

Note

The device meets the requirements for fire protection enclosures in accordance with IEC/EN/UL 61010-2-201. It can therefore be installed without an additional fire protection cover.

Rack mounting

Note**Rack-mount instructions**

- Elevated operating temperature
If installed in a closed or multi-unit rack, the operating ambient temperature may be greater than the room temperature. Install the device in an environment recommended by the manufacturer.
 - Reduced air flow
When installing the device in a rack, ensure that the air flow required for safe operation of the device is guaranteed.
 - Mechanical load
When mounting the equipment in the rack, ensure that a hazardous condition is not caused due to an uneven mechanical load.
 - Circuit overload
When connecting the devices to the power supply, observe the rated values specified on the nameplate of the devices.
 - Reliable grounding
Reliable grounding of rack-mounted equipment should be ensured.
-

Device in the control cabinet

 **DANGER**

Electrocution risk when control cabinet is open

When you open the control cabinet, there might be dangerous voltages at certain areas or components possibly caused by other devices.

Touching these areas or components can cause death or serious bodily injury.

- Always disconnect the cabinet from the mains before opening it.
- Ensure that the power to the control cabinet cannot be turned on accidentally.

2.7 Notes on ambient and environmental conditions

Approvals

 WARNING
Voided approvals If the following conditions are not met when installing the system, the UL 61010-2-201, EN 61010-2-201 approvals are voided and there is a risk of overheating and personal injury. <ul style="list-style-type: none">• You should observe the following information on ambient and environmental conditions.

Ambient and environmental conditions

NOTICE
Ambient conditions and chemical resistance Unsuitable environmental conditions can cause faults or damage the device. In the event of an infringement, the warranty/guarantee pursuant to IEC/EN/UL 61010-2-201 expires. <ul style="list-style-type: none">• Operate the device only in the closed rooms.• Only operate the device in the ambient conditions specified in the technical specifications.• Observe the permitted mounting positions of the device.• Do not obstruct the venting slots of the device.• When the device is operated in severe environments which are subject to caustic vapors or gases, ensure sufficient clean air is provided.• Clean the enclosure surface with a damp cloth and make sure that no water enters the device.

When you plan your project, you should make allowances for:

- The climatic and mechanical environmental conditions specified in the operating instructions.
- Do not operate the device in severe environments which are subject to caustic vapors or gases.
- Avoid extreme ambient conditions such as heat.
- Do not expose the device to direct sunlight or other powerful light sources.
- Install the device in a way that no danger is posed.
- Always maintain a minimum clearance of 50 mm to the area of the ventilation slots and do not cover the ventilation slots of the enclosure.

- Ensure that there is a distance of at least 50 cm at the back of the device, depending on wiring.
- You can install the device without an additional fire protection enclosure. It meets the requirements for fire protection enclosures in accordance with IEC/EN/UL 61010-2-201.
- The device conforms to IP 20 degree of protection on the front. Ensure that there is no splash water in the installation area.

High frequency radiation

 CAUTION
Immunity to RF interference The device has an increased immunity to RF radiation according to the specifications on electromagnetic compatibility in the technical specifications. High frequency radiation above the specified immunity limits can result in malfunctioning of the device. Persons are injured and the plant is damaged. <ul style="list-style-type: none">• Avoid high-frequency radiation.• Remove radiation sources from the environment of the device.• Switch off radiating devices.• Reduce the radio output of radiating devices.• Read the information on electromagnetic compatibility.• Read the information in the technical specifications.

2.8 Information on I/O devices

 CAUTION
Fault caused by I/O devices The connection of I/O devices can cause faults in the device. The result may be personal injury and damage to the machine or plant. <ul style="list-style-type: none">• Only connect I/O devices which are approved for industrial applications in accordance with IEC/EN 61000-6-2 and IEC/EN 61000-6-4.• I/O devices that are not hotplug-capable may only be connected after the device has been disconnected from the power supply.

NOTICE

Damage through regenerative feedback

Regenerative feedback of voltage to ground by a connected or installed component can damage the device.

Connected or built-in I/Os, for example, a USB drive, are not permitted to supply any voltage to the device.

Regenerative feedback is generally not permitted.

Note

When measuring the counter EMF, remember the following:

- The IPC in question must be turned off and the power supply connector must be plugged in.
- During the measurement, all cables from the plant to the IPC should be connected.
- All other components in the plant must be active.

2.9 Notes on device and system extensions

Device and system extensions

 **CAUTION**

Fire hazard due to overheating of the device

Expansion cards generate additional heat. The device might overheat or cause a fire.

- Observe the safety and installation instructions for the expansion cards.
- Observe the max. permissible power consumption values.

NOTICE

Damage caused by device and system extensions

Device and system expansions might contain faults and affect the entire device, machine or plant. They can also violate safety rules and regulations regarding radio interference suppression.

If you install or replace device or system expansions and damage your device, the warranty is voided.

- Always disconnect the power plug before you open the device.
- Only install device or system expansions designed for this device.
- Observe the information on "Electromagnetic compatibility" provided in the technical specifications.

Contact your technical support team or the point of sale to find out which device and system expansions are suitable for installation.

Limitation of liability

- All technical specifications and approvals of the device only apply if you use expansion components that have a valid CE approval (CE mark).
- Observe the installation instructions for expansion components in the associated documentation.
- UL approval of the device only applies when the UL-approved components are used according to their "Conditions of Acceptability".
- We are not liable for functional limitations caused by the use of third-party devices or components.

Installing and connecting the device

3.1 Preparing for mounting

3.1.1 Scope of delivery

Device and hardware for the device

- Rack PC SIMATIC IPC347G
- Keys for front door: 2 keys
- Self-adhesive enclosure feet: 4 units

Supplied data storage medium

On the supplied data storage medium (read only) you will find:

- Software and tools to recover your ordered Microsoft® Windows® operating system
- Device drivers for installation in operating systems
- SIMATIC IPC347G Quick Install Guide
- SIMATIC IPC347G Operating Instructions
- Operating instructions for your ordered Microsoft® Windows® operating system on this device

Operating system

Depending on the ordered device configuration, the device is equipped with or without one of the following installed operating systems.

You can find information on ordered Microsoft® Windows® operating systems under: Important instructions and manuals for operating the device (Page 8) or Technical specifications of the operating systems (Page 75).

Printed documents

- SIMATIC IPC347G Quick Install Guide
- Product Information "Important notes on your device"

3.1.2 Checking the delivery package

 WARNING
Electric shock and fire hazard due to damaged device
Damaged devices due to improper storage or transport may lead to personal injury and/or substantial damage to equipment.
You should observe the warnings in "Note on transport and storage (Page 22)".

Procedure

1. Check the delivery unit for any signs of visible transport damage.
If any transport damage is present at the time of delivery, lodge a complaint at the shipping company in charge. Have the shipper confirm the transport damage immediately.
2. Unpack the device at its installation location.
3. Keep the original packaging in case you have to transport the unit again.
4. Check the scope of delivery (Page 28) for completeness and damage.
Please inform the delivery service immediately if the package contents are incomplete or damaged or do not correspond with your order.
5. Please keep the documentation in a safe place. It is required for initial commissioning and is part of the device.
6. Record the Device identification data (Page 29).

3.1.3 Device identification data

The device can be clearly identified with the help of this identification data in case of repairs or loss.

The following illustrations are examples. The data of your device may differ from the data in these examples.

Product label and component label

The product label and component label are located on the inside of the front door.

Identification data	Where is it?
Order number	①
Serial number	②
Product version	③
Unified Siemens address for product liability	④
Ethernet address (MAC address)	⑤

SIMATIC IPC347G

ORDER NO.: 6AG4012-2....-...	SLOT 1
SERIAL NO.: SVPVFID	SLOT 2
...	SLOT 3
...GB DDR4...	SLOT 4
...GB HDD...	SLOT 5
CPU ...	SLOT 6
PS 1 00-240~ VAC	SLOT 7
Windows 10 Enterprise 2019 LTSC,64bit	
Without extension(hardware)	

ONBOARD MAC-ADDRESSES:

ETHERNET LAN 1: XX:XX:XX:XX:XX:XX	
ETHERNET LAN 2: XX:XX:XX:XX:XX:XX	⑤

SERVICE & SUPPORT
www.siemens.com/asis

COA label

The COA label (Certificate of Authenticity) is located inside the front door.

Note

The COA label is only available for devices delivered with Microsoft® Windows® operating system installed.

Example of the COA label:

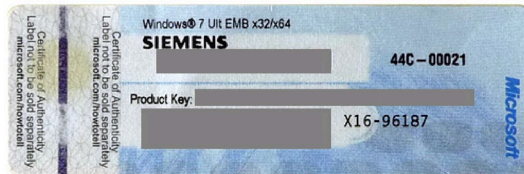

3.2 Mounting the device

3.2.1 Mounting types

Note

If the equipment is used in a manner not specified by the manufacture, the protection provided by the equipment might be impaired.

- The device is approved for indoor operation only.
- When the device is used in the area of Industrial Control Equipment in accordance with UL61010-2-201, the device is classified as "Open equipment".
Open equipment must be installed within an enclosure which protects you from hazards, including mechanical hazards, electrical shock and spread of fire.
- Install the device only in one of the described permitted mounting positions.
- For installation of control cabinet, observe the country-specific regulations.
- Provide adequate volume in the switchgear cabinet for air circulation and heat transport. Keep at least 10 cm between the device and the switchgear cabinet.
- Do not cover the vent slots of the device.
- Ensure that the maximum air intake temperature, measured 5 cm before the air intake opening, does not exceed 40° C. The maximum air intake temperature must be accounted for especially when sizing closed switchgear cabinets.
- The minimum distance between the device and the housing is 10 cm on the air output end.
- Ensure that the installed device does not pose a danger, for example, hit someone by falling over.
- All the external circuit of the device must be SELV circuit.

Horizontal: Mounting on angle brackets

The device can be installed horizontally in control cabinets and 19" rack systems.

Horizontal: Mounting on telescopic rails

The device can be installed horizontally in control cabinets and 19" rack systems.

When telescopic rails are used for mounting, the device can be withdrawn fully from the cabinet or rack. Note the information in "Technical specifications of the telescopic rails (Page 75)".

Horizontal: Mounting on device base

The device can be installed horizontally in control cabinets and 19" rack systems.

Additional installation information

You can also find additional information in the QIG (Quick Install Guide), which comes with your device.

3.2.2 Securing device

WARNING

Dangerous voltage and fire hazard

Improper actions during installation and assembly may lead to personal injury and/or substantial damage to equipment.

You should observe the installation and assembly notes under:

- Notes on mounting (Page 23)
- Notes on ambient and environmental conditions (Page 24)

DANGER

Electrocution risk when control cabinet is open

When you open the control cabinet, there may be a dangerous voltage at certain areas or components.

Touching these areas or components can cause death or serious bodily injury.

- Always disconnect the cabinet from the mains before opening it.
- Ensure that the power to the control cabinet cannot be turned on accidentally.

⚠ CAUTION**Risk of physical injury**

The device is too heavy to be mounted exclusively with the 19-inch brackets of the front panel.

The device may fall down, injure people and get damaged.

- Secure the device using additional measures. The mounting screws of the telescopic rails may not protrude more than 5 mm into the device.
- Use the brackets on the front panel to carry and lift the unit.

Mounting holes

Detailed information on the position of the mounting holes for angle brackets or telescopic rails can be found here: Dimension drawing of the telescope rails (Page 79) and Technical specifications of the telescopic rails (Page 75).

The figure below shows the position of the mounting holes for angle brackets or telescopic rails.

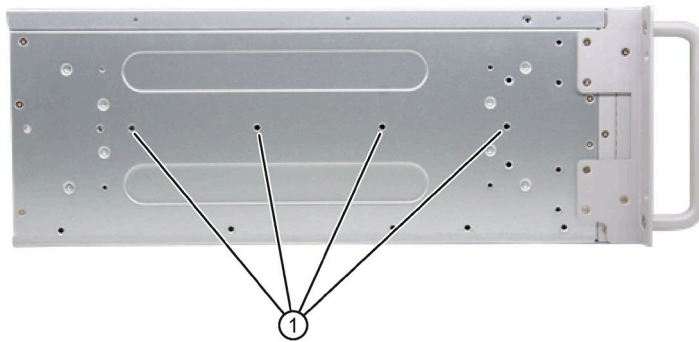

- ① Threaded holes for 3A68-508APZZ3CEB 84H341300 telescopic rails from the company KING SLIDE WORKS CO., LTD or other telescopic rails match the dimensional and technical requirements.

3.3 Connecting the device

3.3.1 Country-specific information on supply voltage

Country-specific information

The power supply cable must conform to the safety regulations of the country in which the devices are installed and bear the marks required in each case.

This device must be equipped with a safety-tested power cord which may only be connected to a grounded shockproof power outlet. Use a flexible cable with the following features:

230 V supply voltage of the USA and Canada

- Type SJT with three conductors
- The connector must be compliant with NEMA 5-15.
- Conductor cross-section ≤ 18 AWG
- Cable length ≤ 4.5 m

120 V supply voltage of the USA and Canada

- Type SJT with three conductors
- The connector must be compliant with NEMA 5-15.
- Conductor cross-section ≤ 18 AWG
- Cable length ≤ 4.5 m

240 V supply voltage

- Type SJT with three conductors
- Conductor cross-section ≤ 18 AWG
- Cable length ≤ 4.5 m

100 V supply voltage

- Type SJT with three conductors
- Conductor cross-section ≤ 18 AWG
- Cable length ≤ 4.5 m

220V supply voltage

- Type RVV with three conductors
- conductor cross-section ≤ 18 AWG
- Cable length ≤ 4.5 m

3.3.2 Connecting the function earth

A connected function earth discharges electrical charges from the metal enclosure.

The function earth also improves the discharge of interference generated by external power cables, signal cables or cables for I/O modules to ground.

The connection for the function earth is labeled with the following symbol:



You can find information on the position of the functional earthing connection under "Rear of the device (Page 12)".

Requirement

- PH2 screwdriver
- Cable lug for M4
- Function earth with minimum cross-section of 2.5 mm² copper cable

Procedure

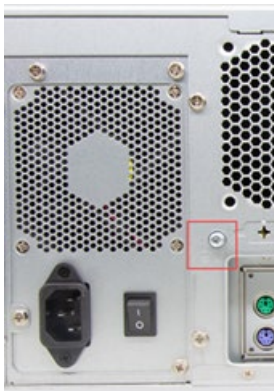

1. Clamp the cable lug on the function earth.
2. Firmly attach the cable lug to the function earth connection on the device using the M4 thread (see part labeled).
3. Connect the function earth to the protective conductor connection of the cabinet or the plant in which the device is installed.

3.3.3 Connecting the power supply

 WARNING
Injury to persons or damage to property when operated on an incorrect power supply system
If you connect the device to an unsuitable power supply, the device receives voltages and currents that are too high or too low.
Injuries to persons, malfunctions or a damage to the device can result.
<ul style="list-style-type: none">• The permissible rated voltage of the device must match the local supply voltage.• Operate the device only in grounded power supply networks (TN networks in accordance with VDE 0100 Part 100 or IEC 60364-1).• Operation in non-grounded or impedance-grounded networks is not permitted.

 WARNING
Risk of electric shock
The on/off button and on/off switch do not fully disconnect the device from the mains.
There is also a risk of fire if the device or connecting lines are damaged.
<ul style="list-style-type: none">• Always fully disconnect the device from the mains voltage before performing work on the device or when the device will not be used over an extended period of time.• For control cabinet mounting: Use a central, easily accessible AC circuit breaker close to the device, if possible.

Requirements

- You have observed the information under "Country-specific information on supply voltage (Page 34)".

Procedure

1. Turn the on-off switch off (position "0"). Information on the position of the on/off switch is available in "Operator controls (Page 15)".
2. Insert the power cable in the corresponding electrical socket. Information on the position of the socket is available in "Power supply connections (Page 15)".
3. Insert the power cable in the electrical socket.
4. Switch the on/off switch to on (position "I").

3.3.4 Connecting I/O devices

**CAUTION****Fault caused by I/O devices**

The improper connection of I/O devices can cause faults in the device.

The result may be personal injury and damage to the machine or plant.

You should observe the warnings relating to the connection of I/O devices in "Information on I/O devices (Page 25)".

Procedure

Note

Use the original connections of the I/O to be connected without adapters or extensions.

1. Connect the I/O devices to the respective interfaces. Information on the position of the interfaces is available in "Interfaces and connections (Page 14)".
2. Secure the cables (Page 38) with strain relief if needed.

Connecting audio devices

Depending on the function, a UAJ connector has 2-4 contact surfaces.

Depending on the function or standard, the assignment of the contacts varies.

The audio controller of the device recognizes the assignments of the contacts of the UAJ connector in accordance with the connected audio device and is automatically configured.

You can connect the following audio devices to the UAJ connection:

- Audio device with line out
- Audio device with line in
- Headphones
- Microphone
- Headset (with headphones and microphone) with the following standards:
 - OMTP: Standard for audio devices from Nokia, etc.
 - CTIA: Standard for audio devices from Apple®

3.3.5 Connecting device to networks

The following options are available for integrating the device in existing or planned system environments and networks.

Ethernet

Wake on LAN and Remote Boot are supported.

You can use the integrated Ethernet interfaces (10/100/1000 Mbps) for communication and data exchange with automation devices, such as SIMATIC S7.

You need the "SOFTNET S7" software package for this.

PROFINET

PROFINET can be operated via:

- Standard Ethernet interfaces (RT)

SIMATIC NET

Use this software package to create, operate and configure an innovative network for Field & Control level. Additional information is available under SIMATIC NET (<https://new.siemens.com/global/en/products/automation/industrial-communication.html>).

The software package and the documentation are not included in the scope of delivery.

Additional information

You can find additional information on the Internet at:

Technical support (<https://support.industry.siemens.com>)

3.3.6 Dual-monitoring

You can operate on up to two monitors with the VGA and DP cables.

The output on the extended monitor can be the same as the main monitor or the extension desktop of the main monitor. You can configure it in windows screen and display setting.

Commissioning the device

4.1 Initial commissioning

For the configuration with operating system pre-installed, the operating system is set up automatically on the device after the initial switch on. The commissioning procedure in this chapter is only applicable to the IPCs with operating system.

For the configurations without operating system pre-installed, contact the operating system provider to install the operating system firstly.

NOTICE
Faulty installation If you change the default values in the BIOS setup or if you turn off the device during the installation, you disrupt the installation and the operating system is not installed correctly. The operating safety of the device and the plant is at risk. Do not switch off the device during the entire installation process. Do not change the default values in the BIOS setup.

Requirements

Ensure the following preparation work have been done before you start the commissioning:

- Peripheral equipments, keyboard, mouse and monitor are connected.
- The power supply is connected. (Page 36)

Note

The device can be supplied without an operating system. The following sections describe commissioning with an operating system.

Procedure

1. Press the on/off button.

Press the on/off button at the front of the device behind the front panel door. Information on the position of the switch and button can be found at "Operator controls (Page 15)".

The green POWER LED lights up. The module carries out a self-test.

2. Follow the instructions on the screen.

Press <ESC> or <DELETE> to enter setup.

Note

Once the operating system has been set up, the device may restart.

Result

The interface of the operating system is displayed every time you turn on the device and after the startup routine.

4.2 Switching off the device

Shutting down the operating system

For active operating system:

- Shut down the operating system properly.

For inactive operating system

- Briefly press the on/off button. Information on the position of the button is available under "Operator controls (Page 15)".

Result

The "POWER" operating display is lit green.

The device is switched off but not fully disconnected from the line voltage.

Fully disconnecting the device from the line voltage

 **WARNING**

Risk of electric shock

The on/off button and on/off switch do not fully disconnect the device from the mains.

There is also a risk of fire if the device or connecting lines are damaged.

- Always fully disconnect the device from the mains voltage before performing work on the device or when the device will not be used over an extended period of time.
- For control cabinet mounting: Use a central, easily accessible AC circuit breaker close to the device, if possible.

- Shut down the operating system and unplug the power plug from the rear of the device, see "Power supply connections (Page 15)".

The device is switched off and fully disconnected from the mains voltage. No trickle current is flowing.

Hardware reset

With the hardware reset, you can restart the device if it does not respond to keyboard or mouse input. Any running operating system will not shut down safely.

NOTICE

Data loss

If a hardware reset is performed, the device undergoes a hard reboot.

- Data in the main memory is deleted.
- Data on the data storage media might be lost.
- The device might be damaged.

Perform a hardware reset only in the case of an emergency.

Hardware reset with on/off button:

- Press the on/off button for more than 4 seconds.
 - The unit switches off.
 - Press the power button again to turn the device back on.

Information on the position of the buttons is available under "Operator controls (Page 15)".

Operating the device

5.1 Opening the front door

Procedure

1. Unlock the front door with the key ①.
2. Open the front right door in the direction of the arrow.

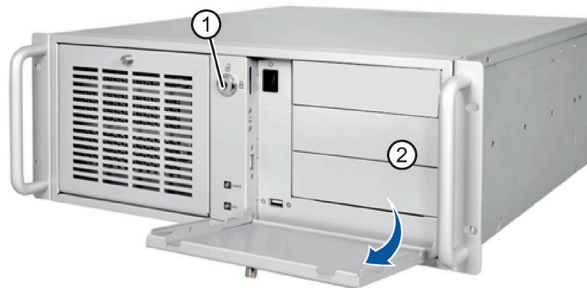

5.2 Monitoring functions

You can monitor the following device functions:

Monitoring	Description	Status display and actions
Temperature monitoring	Monitor the temperature of CPU and motherboard.	<ul style="list-style-type: none"> • The onboard hardware monitor automatically detects and displays the CPU temperatures. • The onboard hardware monitor automatically detects and displays the air inlet temperature. • The onboard hardware monitor automatically detects and displays the air outlet temperature.
Fan monitoring	Monitor the CPU FAN and chassis Fan.	<p>Check the function in the Hardware Monitor Menu (Page 93) of BIOS:</p> <ul style="list-style-type: none"> • CPU FAN control: <ul style="list-style-type: none"> – [Auto Mode]: CPU Fan speed change based on CPU temperature. • CHA Fan1 Control <ul style="list-style-type: none"> – [Auto Mode]: Chassis Fan speed change based on mother board temperature. – [Silent Mode]: Chassis Fan speed keep stable and no noise. – [Disabled Mode]: Uses Maximum speed • CHA Fan2 Control <ul style="list-style-type: none"> – [Auto Mode]: Chassis Fan speed change based on mother board temperature. – [Silent Mode]: Chassis Fan speed keep stable and no noise. – [Disabled Mode]: Uses Maximum speed

6.1 Open the device

WARNING

Risk due to unauthorized opening and improper repairs or expansions

Improper procedure when carrying out expansions may result in substantial damage to equipment or endanger the user.

If you install or exchange system expansions and damage your device, the warranty becomes void.

For this reason, please observe the information in "Notes on device and system extensions (Page 26)".

WARNING

Malfunctions and electric shock

Improper intervention in the device endangers operational reliability and may damage the device.

The results are personal injuries and damage to the plant.

Take the following precautions:

- Always disconnect the power plug before you open the device.
- Close the device after every intervention.

NOTICE

Electrostatic sensitive devices (ESD)

The device contains electronic components that may be destroyed by electrostatic charges. This can result in malfunctions and damage to the machine or plant.

Take corresponding precautionary measures before you open the device.

Requirement

- The front door is open; see "Opening the front door (Page 42)".
- The device is fully disconnected from the line voltage, see "Switching off the device (Page 40)".
- All connection cables are unplugged.
- PH2 screwdriver

Procedure

1. Remove the retaining screws ①.

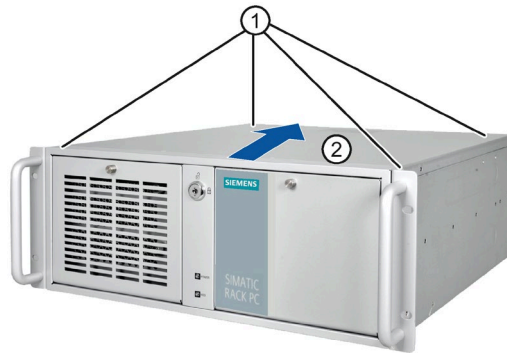

2. Move the cover in the direction as the arrow.
3. Lift the cover from the back and remove it.



6.2 Expansion cards

6.2.1 Usable expansion cards

Expansion cards that comply with the following standards are supported:

- PCI; Rev 2.3
Expansion cards with 3.3 V and 5 V supply voltage can be operated
- PCIe; Gen. 1, Gen. 2, Gen. 3(only supported for PCIe X16 slot)

Note

Expansion card specification

The dimensions of the cards cannot exceed the specified dimensions. If the height of the card exceeds the specified dimension, you may experience contact problems, malfunctions and difficulties with the assembly.

The permitted expansion card dimensions are specified in the section Dimension drawing of the expansion cards (Page 79).

The PCI card is limited to 5 V and universal board.

The total power consumption of the modules is not permitted to exceed 75W in total.

6.2.2 Installing expansion cards

Requirement

- You are familiar with the information on expansion cards and the conditions of use of expansion cards, see "Useable expansion cards (Page 46)".
- The device is open, see important information in "Open the device (Page 44)".

Procedure

1. Remove the retaining screw and remove the card holder.

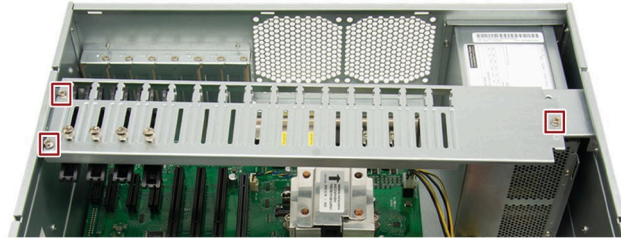

2. Remove the slot bracket of the slot for the expansion card.



3. Insert the expansion card into the slot.

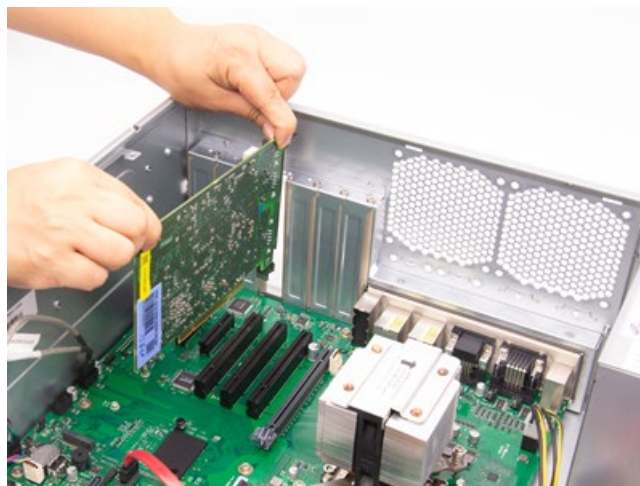

4. Secure the expansion card with the designated screw.

6.3 Memory modules

5. Loosen the bracket by unscrewing its screw ① and place it ② on the expansion card.

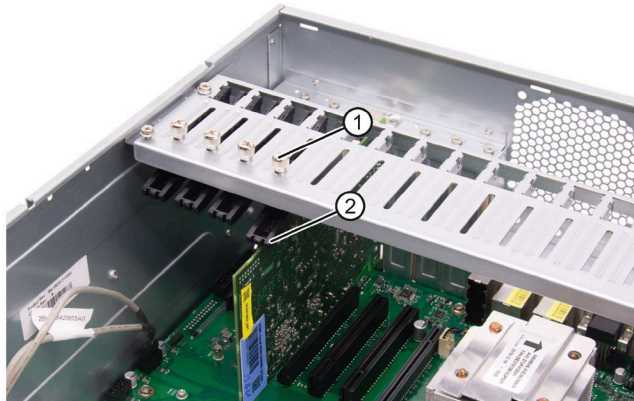

6. Secure the bracket.
7. Close the device.

6.3 Memory modules

6.3.1 Usable memory modules

Dual channel memory

The motherboard provides two DDR4 memory sockets and supports dual channel technology. The memory capacity of the device can be upgraded to a maximum of 32 GB. You can use approximately 3.2 GB of this memory in a 32-bit operating system and much more in a 64-bit operating system.

The table below shows the supported memory types of motherboard.

Module type	Module Size	Description
DDR4-SDRAM	4 GB	DDR4-2133Mhz-512M x 64-UDIMM-288 pin
DDR4-SDRAM	8 GB	DDR4-2133Mhz-1G x 64-UDIMM-288 pin
DDR4-SDRAM	16 GB	DDR4-2133Mhz-2G x 64-UDIMM-288 pin

6.3.2 Installing memory modules

Requirement

- You have noted the information on combination options and the conditions of use of memory modules under "Usable memory modules (Page 48)".
- The device is open, see important information in "Open the device (Page 44)".
- If necessary, the expansion cards may be removed for easier access to the memory modules, see "Changing the power supply (Page 60)".

To install the memory module



WARNING

- Only install memory modules designed for the default motherboard.
- Recommend selecting memory modules with the same brand, capacity, speed, and chips if you use multiple Memory Modules.
- Unplug the power cord from the power outlet before installing Memory Module.
- A memory module can be installed only when the direction is correct. Switch the direction if the memory cannot be inserted into the memory socket.
- DDR2 and DDR3 memory modules are not compatible. Please make sure to install DDR4 Memory Module on this motherboard.

Follow the steps below to install memory module on motherboard memory sockets:

1. Press the retaining clips outward to unlock the memory socket.
2. Align a memory module on the socket. Note that the notch on the memory must match the alignment key on the memory socket.

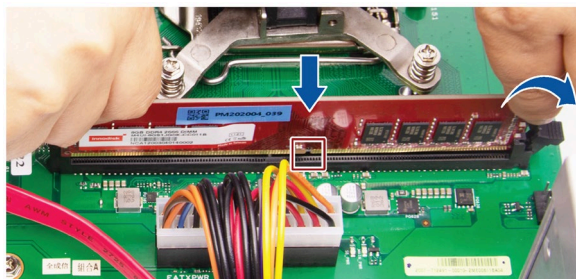

3. Insert and press the memory module into the socket until the retaining clips snap back to the original place, and the memory module is seated properly.

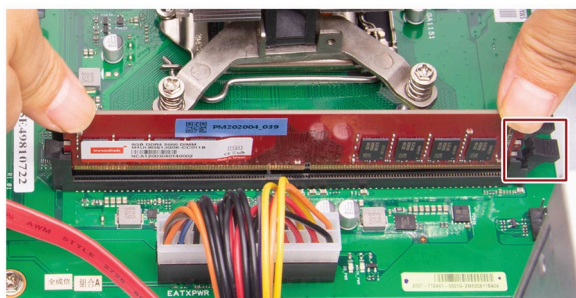

6.4 Drives (HDD/SSD)

6.4.1 Installation options for drive

The drive modules are horizontal slot. The SSD and HDDs (with a 5.25" to 2.5" converter) can be installed in the slots.



Note

If the device is permanently installed, mounted on telescopic rails, it can only be subjected to the vibration stresses described below during operation.

The maximum permitted power loss of the expansion cards is 75 W.

You can install the HDD or SSD in the drive cage at various mounting locations.

You can find information on the mounting locations under:

- Drive cage (Page 13)

If HDD/SSDs are installed in one of the mounting locations, these may be exposed to the following vibration stresses during operation:

- For HDD:
 - 10 to 58 Hz: 0.015 mm
 - 58 to 200 Hz: 1.96 m/s²
- For SSD:
 - 10 to 58 Hz: 0.0375 mm
 - 58 to 200 Hz: 4.9 m/s²

Vibrations above 500 Hz are not permitted.

6.4.2 Removing the drive module

Requirement

- The device is fully disconnected from the line voltage, see Switching off the device (Page 40).
- PH2 screwdriver

Procedure

1. Unlock the front door and open the right-front door.

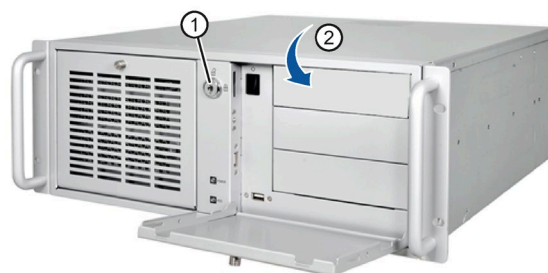

2. Remove the top cover.
3. Disconnect the power supply and data cables.

4. Remove the highlighted five screws.



5. Lift the drive cage completely out of the device.

6.4.3 Installing the drive (HDD/SSD)

You can find information on the correct mounting location for 5.25" drives in a drive cage under "Installation options for drive (Page 50)".

Requirement

- An original spare part, i.e. an "Assembly Kit HDD/SDD for 5.25" tray" approved for this device.
- The device is fully disconnected from the line voltage, see "Switching off the device (Page 40)".
- The device is open, see important information in "Open the device (Page 44)".
- The drive bay is taken out of the chassis.
- PH2 screwdriver

Procedure

1. Remove the drive module (Page 51).
2. Secure the hard disk in the corresponding slot.



Note

- If you want to install a 2.5" hard disk drive or 3.5" hard disk drive, you need to install a corresponding converter in addition.
 - Recommend installing the hard disk in the middle slot of the drive module.
-

3. Install the driver cage again.
4. Connect the power and data cables to the drive.
5. Install the drive bay according to the reverse steps of removing the drive bay.

6.4.4 Removing and installing internal HDD/SSD

Requirement

- The device is fully disconnected from the line voltage, see "Switching off the device (Page 40)".
- The device is open, see important information in "Open the device (Page 44)".
- The drive bay is taken out of the chassis.

Procedure

Loosen the four screws ① on the drive bay plate and remove the hard disk from the drive bay.

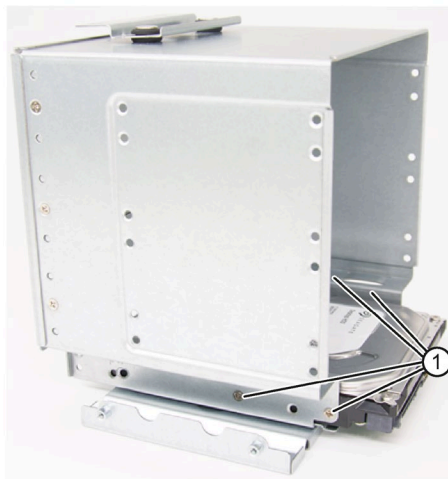

Procedure for installing the hard disk drive

Place the hard disk onto the drive bay plate and secure the drive with four screws ①.

Device maintenance and repair

7.1 Repair information

 WARNING
<p>Risk due to unauthorized opening and improper repairs or expansions</p> <p>Improper procedure when carrying out expansions may result in substantial damage to equipment or endanger the user.</p> <p>If you install or exchange system expansions and damage your device, the warranty becomes void.</p> <p>For this reason, please observe the information in "Notes on device and system extensions (Page 26)".</p>

7.2 Maintenance intervals

To maintain high system availability, we recommend the preventative replacement of those PC components that are subject to wear. The table below indicates the intervals for this replacement.

Component	Replacement interval
Drives	3 years
Backup battery	5 years
Fan	5 years
Filter pad	Depending on the degree of soiling

7.3 Removing and installing hardware

7.3.1 Replacing the filter

Requirement

- The device is fully disconnected from the line voltage, see "Switching off the device (Page 40)".
- The fan cover has been removed; see "Replacing the device fan (Page 57)".
- An original spare part, for example, a filter pad with the same type.

Procedure - Removing the filter

1. Unlock the front cover with the key ①.

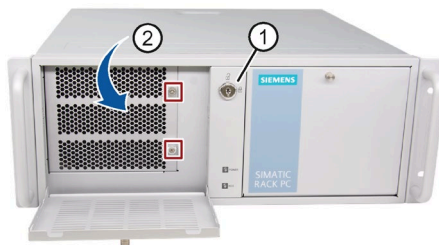

2. Pull the handle in the direction of the arrow ② to open the left-front door.
3. Unscrew the marked screws.
4. Pull the marked screw to open the fan bracket.
5. Remove the filter in the direction of the arrow.



Procedure - Installing the filter

To install the filter, follow the steps for removing it in reverse order.

7.3.2 Replacing the device fan

Requirement

- The device is fully disconnected from the line voltage, see "Switching off the device (Page 40)".
- The front panel cover is open.
- A fan with the same type.
- PH2 screwdriver

Procedure - Removing the fan

1. Unlock the front cover with the key ①.

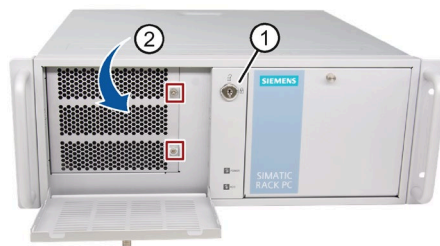

2. Pull the handle in the direction of the arrow ② to open the left-front door.
3. Unscrew the marked screws.
4. Pull the marked screws to open the fan bracket.



5. Remove the highlighted screws.
6. Remove the fan in the direction of the arrow.
7. Pull the fan plug from the connector.

Procedure - Installing the fan

To install the fan, follow the steps for removing it in reverse order. During installation, make sure that the arrow on the fan points away from the fan bracket.

7.3.3 Changing the backup battery

 **WARNING**

Risk of explosion and release of harmful substances

Improper use and handling of lithium batteries can result in an explosion of the batteries.

Explosion of the lithium batteries and the resulting release of harmful substances can cause severe physical injury. Damaged batteries jeopardize the function of the device.

- Replace spent batteries promptly. See information in "Maintenance intervals (Page 55)".
- Replace the lithium battery only with an identical battery or types recommended by the manufacturer.
- Do not throw lithium batteries into fire, do not solder on the cell body, do not recharge, do not open, do not short-circuit, do not reverse polarity, do not heat above 100 °C and protect from direct sunlight, moisture and condensation.

Prior to replacement

 **WARNING**

Risk of explosion and release of harmful substances

An explosion or fire HAZARD could occur through fitting a battery of the wrong type.

Improper handling of lithium batteries also can result in an explosion of the batteries.

Explosion of the batteries and the released pollutants can cause severe physical injury. Aged batteries jeopardize the function of the device.

Note the following when handling lithium batteries:

- Replace the battery every 5 years.
- Replace the lithium battery only with the type recommended by the manufacturer. The new lithium battery must be certificated by UL and meet the following requirements:
 - Type: CR2032
 - Rated voltage: 3 VDC
 - Max abnormal charging current: 10 mA
- For any requirements on product maintenance, contact Siemens Technical support (Page 114).
- Do not throw lithium batteries into fire, do not solder on the cell body, do not recharge, do not open, do not short-circuit, do not reverse polarity, do not heat above 100°C and protect from direct sunlight, moisture and condensation.

 **WARNING**

Risque d'explosion et d'émission de substances nocives

l'installation d'une pile ou d'un accumulateur de type inadéquat peut provoquer un DANGER d'explosion ou d'incendie.

Une manipulation non conforme des piles au lithium peut conduire à leur explosion.

L'explosion des piles et l'émission de polluants qui en résulte peuvent entraîner de graves lésions corporelles. Des piles usagées constituent un danger pour le fonctionnement de l'appareil.

Observez les remarques suivantes lorsque vous manipulez des piles au lithium :

- Remplacez la pile tous les 5 ans.
- Remplacez la pile au lithium uniquement par une pile du type recommandé par le constructeur. La nouvelle pile au lithium doit avoir une certification UL et satisfaire aux exigences suivantes :
 - Type : CR2032
 - Tension nominale : 3 V CC
 - Courant de charge anormal max. : 10 mA
- Pour toute demande concernant la maintenance du produit, contactez le support technique (Page 114) Siemens.
- Ne jetez pas au feu des piles au lithium, n'effectuez pas de soudage sur la pile, ne la rechargez pas, ne l'ouvrez pas, ne la court-circuitiez pas, n'intervertissez pas les pôles, ne la chauffez pas à plus de 100 °C et protégez-la de l'ensoleillement direct, de l'humidité et de la condensation.

NOTICE

Disposal of batteries

Batteries do not belong in domestic garbage. The user is legally obliged to return used batteries.

Used batteries pollute the environment as special waste. You as a user are liable to prosecution if you do not properly dispose of batteries.

Observe the following when disposing of batteries:

- Dispose of used batteries as hazardous waste in accordance with local regulations.
- You can return used batteries to public collection points and wherever batteries of the type in question are sold.
- Label the battery container "Used batteries".

Requirement

- An original spare part, for example, a backup battery with the same type (article number of lithium battery: A5E00331143)
- Record the current configuration data in the BIOS setup. Note that the firmware settings as the configuration data of the device is deleted when the battery is replaced.

- The device is open, see important information in "Open the device (Page 44)".
- You have observed the local regulations relating to the disposal of used batteries.

Procedure

1. Remove the expansion cards, if necessary.
2. Remove the battery from socket.

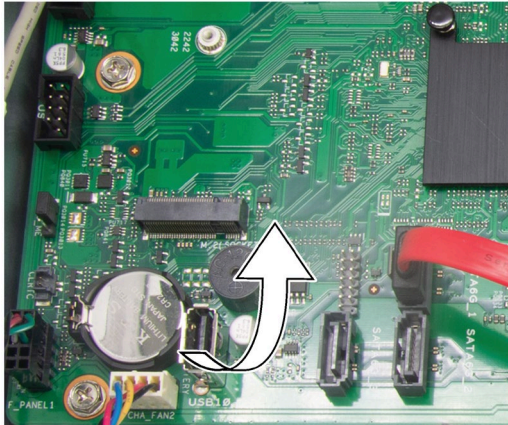

3. Press the new battery into the socket applying slight pressure.
4. Close the device.
5. Reconfigure the BIOS setup.

Note

The configuration data of the device may be deleted when the battery is replaced. Record the current configuration data in the BIOS setup.

7.3.4 Changing the power supply

Requirement

- The device is fully disconnected from the line voltage, see "Switching off the device (Page 40)".
- The device is open, see important information in "Open the device (Page 44)".
- An original spare part, for example, a power supply with the same type.
- PH2 screwdriver

Procedure

1. Disconnect the cables from the drives and the motherboard.
2. Remove the cable ties securing the power cables in the enclosure.
3. Remove the four fixing screws that are marked in the following figure.



4. Pull the power supply upward and out of the housing.
5. Install the new power supply.
6. Fasten the power supply with the screws shown.
7. Connect the cables to the drives and the motherboard.
8. Use cable ties to reattach the power supply cables to the enclosure.
9. Close the device.
10. Check the safe state of the device.
11. Switch on the power supply.

7.3.5 Replacing the processor

Requirement

- The device is fully disconnected from the line voltage, see "Switching off the device (Page 40)".
- The device is open, see important information in "Open the device (Page 44)".
- An original spare part, for example, a processor with the same type.

Only an approved processor is permitted to be installed on the motherboard.

NOTICE

Damage to the processor

If the processor is operated with a higher clock frequency than permitted, it can be destroyed or cause loss of data.

- Operate the processor only at a clock frequency that is equal to or less than the permitted clock frequency.

Procedure

1. Unlatch the fan rack on the heat sink and remove it.
2. Remove the highlighted fan connector.

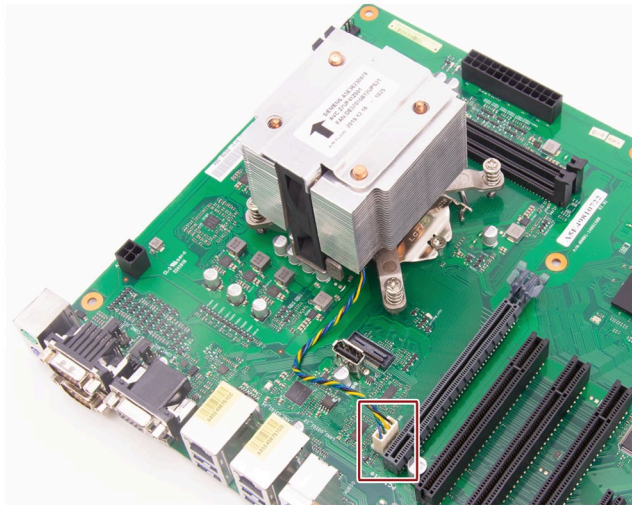

3. Remove the highlighted screws.

The fourth screw is hidden by the heat sink in the figure.

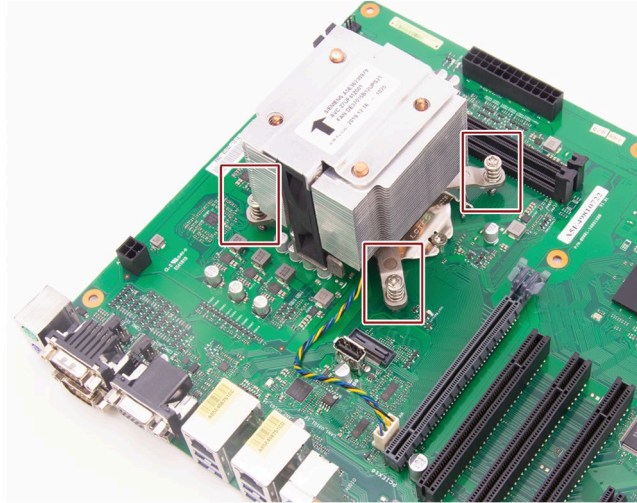

4. Remove the heat sink.
5. Unlock the socket and lift the socket cover.
6. Remove the processor.
7. Install the new processor on the socket, as shown in the figure.

When installing the CPU, make sure you aligned the highlighted arrow on the processor with pin 1 in the CPU socket.

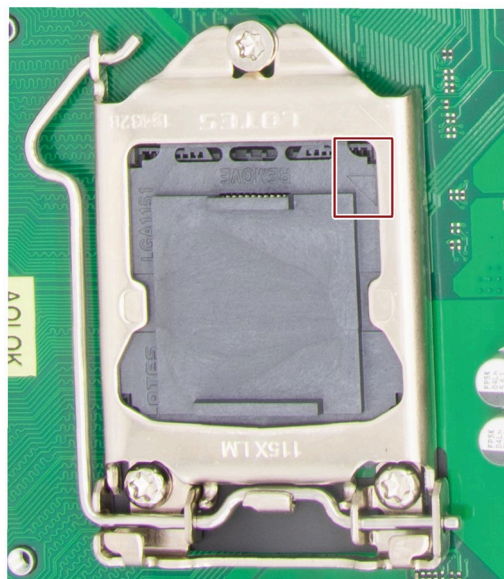

Processor type and clock frequency

If you use a processor of a different type, perform the BIOS update firstly. During the BIOS update, the microcode matching the processor is loaded. Contact the SIEMENS support to update the BIOS if you changed a different processor.

Note

Damage to the processor due to high clock frequency

If the installed processor is operated with a higher clock frequency than permitted, it can be destroyed or cause data loss.

Operate the processor only at a clock frequency that is equal to or less than the permitted clock frequency.

7.3.6 Replacing the motherboard

Requirement

- The device is fully disconnected from the line voltage, see "Switching off the device (Page 40)".
- The device is open, see important information in "Open the device (Page 44)".
- An original spare part, that is a motherboard of the same type.
The motherboard as spare part is supplied without processor and memory modules.
- Note that the firmware settings as the configuration data of the device is deleted when the motherboard is replaced.
You can find information on this in the detailed firmware/BIOS description, see BIOS description (Page 83).
- Screwdriver T10 for fixing screws of the motherboard

Procedure

1. Remove the unnecessary modules from the slots, for example, the expansion card.
2. Note the assignment of all cables to the motherboard.

3. Disconnect all cables from the motherboard.
4. Remove the nine screws indicated in the following figure.

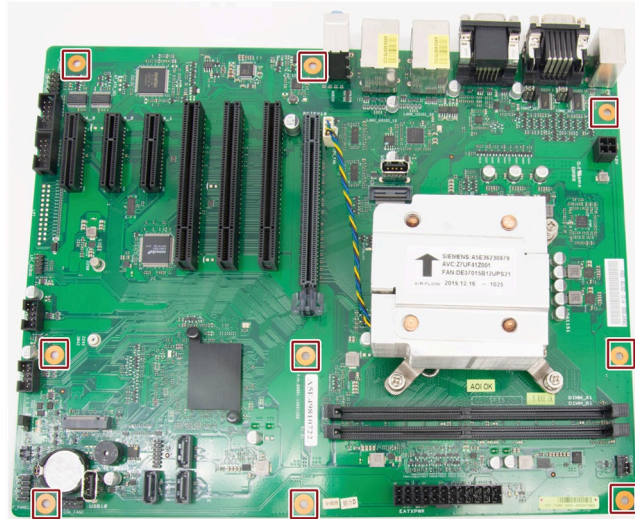

7.4 Installing operating system, software and drivers

Information on installation of the operating system is available on the Internet:

- Microsoft® Windows® 10
(<https://support.industry.siemens.com/cs/ww/en/view/109749498>)

Note

- Before installing Windows 10, set the "Boot mode select" as **UEFI** in BIOS. On how to set the boot mode, refer to Boot menu (Page 94).
-

7.4.1 Installing software and drivers

Requirements

- Windows 10 operating system is installed in your IPC.
- You need to connect a mouse, a monitor and a keyboard to your PC.
- You also need the supplied USB stick to your PC.

Drivers list

The following drivers need to be installed on your device:

Operating system	Drivers needed
Windows 10	<ul style="list-style-type: none">• Step 1: Intel(R) Chipset Device Software• Step 2: Intel(R) Management Engine• Step 3: Intel(R) Network Connections Driver• Step 4: Intel(R) Graphics Driver• Step 5: Realtek High Definition Audio Driver• Step 6: Nuvoton SIO COMMPort Driver

Procedure

1. Insert the provided USB stick into the device.
2. Start the "Documentation and Drivers" suite from the USB flash drive by executing the "START_DocuAndDrivers.CMD" file.
3. Install the desired software and drivers.
4. Follow the below steps and click the icon  to install the required driver.

Note

For a new installation of Windows operating systems, the chipset driver must be installed before all other drivers, if required.

Step 1: install the chipset driver

1. Click **Step 1: Intel(R) Chipset Device Software**.
2. Click  to install the chipset driver.
3. Click **Next** to continue.
4. Click **Accept** to accept the license agreement.
5. Click **Install** to allow the computer to start the installation.
The installation starts.
6. Click **Yes** to confirm the user account control question.
7. Click **Finish**.
The chipset installation is completed.

Step 2: install the Management Engine driver

1. Click **Step 2: Install: Intel(R) Management Engine**.
2. Click  to install the Management Engine driver.
3. Click **Yes** to confirm the user account control question.
4. Click **Next** to continue.
5. Select the radio button before "**I accept the terms in the License Agreement**", and click **Next** to accept license agreement.
6. Select destination folder and click **Next** to start the driver installation.
7. Click **Finish**.

The installation is completed.

Step 3: install the Network Connection driver

1. Click **Step 3: Intel(R) Network Connections Driver**.
2. Click  to install the LAN driver.
3. Click the **Install Drivers and Software** button in the pop-up window.
4. Click **Yes** to confirm the user account control question.
5. Click **Next** to continue.
6. Select the radio button before "**I accept the terms in the license agreement**", and click **Next** to accept license agreement.
7. Set the setup option as you like and click **Next**.
8. Click **Install** to start the driver installation.
9. Click **Finish**.

The installation is completed.

Step 4: install the Graphic driver

1. Click **Step 4: Intel(R) Graphics Driver**.
2. Click  to install the Graphic driver.
3. Click **Yes** to confirm the user account control question.
4. Click **Next** to continue.
5. Click **Yes** to accept license agreement.
6. Click **Next** to confirm the *Readme File Information* and move on.

The installation starts.

7. Click **Next** to continue.
8. Select the radio button next to **“Yes, I want to restart my computer now.”** and click **Finish** to restart the computer for the changes to take effect.

Step 5: install the Audio driver

1. Click **Step 5: Realtek High Definition Audio Driver.**
2. Click  to install the Audio driver.
3. Click **Yes** to confirm the user account control question.
4. Click **Next** to continue.
5. Click **Install** to continue the installation.
6. Select the radio button next to **“Yes, I want to restart my computer now.”** and click **OK** to restart the computer for the changes to take effect.

Step 6: install the SIO driver

1. Click **Step 6: Nuvoton SIO COMMPort Driver.**
2. And then click  to install the Super IO driver.
3. Click **Yes** to confirm the user account control question.
4. Click **Yes** to continue.
5. Click **Install** to continue the installation.
6. Select the radio button next to **“Yes, I want to restart my computer now.”** and click **OK** to restart the computer for the changes to take effect.

7.5 Recycling and disposal

Due to their low level of pollutants, the devices described in these operating instructions can be recycled. Contact a certified disposal service company for environmentally sound recycling and disposal of your old devices.

7.6 Beep code

Beeps	Description
1 short beep	Power on correctly
4 short beeps	Memory error
5 short beeps	Keyboard error

Technical specifications

8.1 Applicability of technical specifications

Note

The following technical specifications only apply under the following conditions:

- The device is in good working order.
- The fan cover and filter pad are installed.
- The device is closed.
- The connected I/O devices meet the requirements for the respective area of application (interference emission according to EN 61000-6-3 / IEC 61000-6-3, immunity to interference according to EN 61000-6-2 / IEC 61000-6-2).

8.2 General technical specifications

See the note in "Applicability of technical specifications (Page 69)".

Article number	6AG4012-2...-.... (for details, refer to the ordering documentation)
Dimensions	481 × 176 × 509 (W × H × D in mm)
	Detailed dimensional specifications can be found in "Dimension drawings (Page 78)".
Weight	13.3 up to 17 kg; depending on the equipment
Power Supply	<ul style="list-style-type: none"> • Input Rating: 100 VAC to 240 VAC ; 6 to 3A; 60 to 50Hz • Rated output power: 350W (+3.3V & +5V ≤ 105W)
Power consumption	<ul style="list-style-type: none"> • Full load (100%, 350 W) at 82% efficiency • Typical load (50%, 175 W) at 85% efficiency • Light load (20%, 70 W) at 82% efficiency
Current output (DC)	<ul style="list-style-type: none"> • +5 V/16 A, +3.3 V/19 A • 105 W permitted in total • +12 V1/17 A, +12 V2/17 A • -12 V/0.3 A, +5 V_{aux}/2.5 A <p>The total sum of all voltages is max. 210 W</p>
Noise emission	< 55 dB (A)
Degree of protection	<ul style="list-style-type: none"> • IP 20 on the rear according to IEC 60529
Safety	
Protection class	Protection class I compliant with IEC 61140
Degree of pollution	Device is designed for environments with pollution degree 2

8.3 Current/power requirements and power supply

Transient overvoltage	Device is designed for connection to supply with overvoltage category II (transient overvoltages up to 2500 V)
Safety regulations	<ul style="list-style-type: none"> • IEC/EN/UL 61010-1 • IEC/EN/UL 61010-2-201 • IEC/EN/UL 62368 • CAN/CSA-C22.2 No. 61010-1 • CAN/CSA-C22.2 No. 61010-2-201

¹ Only with protected installation, see "Notes on ambient and environmental conditions (Page 24)"

8.3 Current/power requirements and power supply

8.3.1 Power requirements of the components (maximum values)

Component	Voltage					
	+5 V	+3.3 V	+12 V1	+12 V2(CPU)	-12 V	5 V aux
motherboard with processor and heat sink	2.5 A	1.2 A	4.6 A		0.1 A	0.3 A
Front fan			0.5 A			
Basic system ¹	2.5 A	1.2 A	5.1 A		0.1 A	0.5 A
Expansions						
Hard disk drive SATA ¹	0.6 A		0.8 A			
DVD ROM ¹	0.9 A		0.8 A			
DVD writer ¹	1.1 A		1.4 A			
Single lines of current (max. permitted) ²	25 A	25 A	16 A	16 A	0.8 A	3 A
Total power consumption, permitted	210 W					
Efficiency of the power supply ¹	AC power supply: approx. 85% (230 V AC/120 V AC) with typical load (50%) and 82% (230 V AC/120 V AC) with full (100%) or light load (20%)					

¹ Depends on the selected device configuration.

² The max. permitted accumulated power of the +5 V and + 3.3 V is 130 W.

8.3.2 Technical specifications of basic power supply

Output voltage

Voltage	Maximum current	Voltage stability
+12 V	17 A	± 5%
+12 V	17 A	± 5%
-12 V	0.3 A	± 10%
+5 V	16 A ¹	± 5%
+3.3 V	19 A ¹	± 5%
+5 V _{aux}	2.5 A	+5%

¹ The total output of the +5 V and +3.3 V voltage must be ≤ 105 W.

The inrush current is:

- For 110 VAC: Maximum 35 A, 5 ms
- For 230 VAC: Maximum 90 A, 5 ms

8.4 Electromagnetic compatibility

See the note in "Applicability of technical specifications (Page 69)".

Interference emission	EN 61000-6-4 CAN/CSA CISPR22 Class A, EN 55032 Class A; FCC Class A; EN 61000-3-2 class D, EN 61000-3-3
Emitted interference	Conducted Emission (AC): IEC 61000-6-4 + A1, CISPR 22 <ul style="list-style-type: none"> • 0.15 to 0.5 MHz: 79 dB (µV) QP, 66 dB (µV) A • 0.5 to 30 MHz: 73 dB (µV) QP, 60 dB (µV) A Radiation Emission: IEC 61000-6-4, CISPR 22 <ul style="list-style-type: none"> • 30 to 230 MHz: 40 dB(µV/m) QP (10 m distance) • 230 to 1000 MHz: 47 dB (µV/m) QP (10 m distance) • 1 to 3 GHz: 76 dB (µV/m) P; 56 dB (µV/m) A (3 m distance) • 3 to 6 GHz: 80 dB (µV/m) P; 60 dB (µV/m) A (3 m distance) Harmonic currents: EN 61000-3-2 class D Voltage fluctuation and flicker: EN 61000-3-3
Noise immunity on supply lines	± 2 kV; according to IEC 61000-4-4; burst ± 1 kV line-to-line; according to IEC 61000-4-5; ± 2 kV line-to-earth; according to IEC 61000-4-5;
Noise immunity on signal lines	± 2 kV; according to IEC 61000-4-4; burst; length > 30 m ± 1 kV ; according to IEC 61000-4-4; burst; length < 30 m ± 2 kV shielding-to-earth; according to IEC 61000-4-5; surge; length > 30 m
Immunity to discharges of static electricity	± 4 kV contact discharge (according to IEC 61000-4-2) ± 8 kV atmospheric discharge; (according to IEC 61000-4-2)

8.5 Ambient conditions

Immunity to RF interference	<p>Radiation Immunity (according to IEC 61000-4-3)</p> <ul style="list-style-type: none"> • 10 V/m; 80 up to 1000 MHz 80% AM (1 kHz) • 3 V/m; 1.4 to 2 GHz 80% AM (1 kHz) • 3 V/m; 2 to 6 GHz 80% AM (1 kHz) <p>Conducted Immunity (according to IEC 61000-4-6)</p> <ul style="list-style-type: none"> • 150 kHz to 80 MHz: 10 V, 80% AM (1 kHz)
Magnetic field	30 A/m; 50 Hz; 60 Hz (according to IEC 61000-4-8)

8.5 Ambient conditions

See the note in "Applicability of technical specifications (Page 69)".

Climatic ambient conditions	
Temperature	Tested according to IEC 60068-2-2; IEC 60068-2-1; IEC 60068-2-14
Operation	+5 °C up to +40 °C Gradient: ≤ 10 K/h; no condensation
Storage/transport	-20 °C up to +60 °C Gradient: ≤ 20 K/h; no condensation
Relative humidity	Tested according to IEC 60068-2-78; IEC 60068-2-30
Operation	5% up to 80% at 25 °C; no condensation Gradient: ≤ 10 K/h; no condensation
Storage/transport	5% up to 95% at 25 °C; no condensation Gradient: ≤ 20 K/h; no condensation
Atmospheric pressure	
Operation	1013 up to 795 hPa, corresponds to an altitude of 0 m to 2000 m
Storage/transport	1013 up to 660 hPa, Corresponds to an altitude of 0 m to 3500 m
Mechanical ambient conditions	
Vibration	Tested according to IEC 60068-2-6;
Operation	With HDD: 10-58 Hz: 0.015mm; 58-200 Hz:1.96 m/s ² ; 10 cycles With SSD: 10-58 Hz: 0.0375mm; 58-200 Hz:4.9 m/s ² ; 10 cycles
Storage/transport	5 to 8.4 Hz, amplitude 3.5 mm; 8.4 to 500 Hz: 9.8 m/s ²
Resistance to shock	Tested in accordance with IEC 60068-2-27
Operation	With HDD: Half-sine: 9.81 m/s ² , 20 ms, 3 shocks per axis With SSD: Half-sine: 150 m/s ² , 11 ms, 3 shocks per axis
Storage/transport	Half-sine; 250 m/s ² ; 6 ms; 1000 shocks per axis
Special features	
Quality assurance	In accordance with ISO 9001
Altitude of operation (m)	Up to 2000 m

8.6 Technical specifications of the drives

See the note in "Applicability of technical specifications (Page 69)".

Information on the drives is available in your order documents.

Drive	Maximum number of drives	Types of drive
HDD	2 (depends on the selected configuration)	<ul style="list-style-type: none"> 3.5" SATA, 6 GB/s; 1 TB
SSD	1	<ul style="list-style-type: none"> 256 GB 512 GB

8.7 Technical specifications of the motherboard

See the note in "Applicability of technical specifications (Page 69)".

Chipset	Intel® H110 Chipset PCH
Processor	<ul style="list-style-type: none"> Intel® 6th and 7th generation Core or Pentium 14nm LGA 1151 socket Processor, support 65W CPU
Slots for memory modules	2 x DIMM slots for DDR4 2133, expandable to 32 GB
Main memory	4 up to 32 GB, DDR4 SDRAM PC4-3200T Max. of 2.8 GB can be used for 32-bit versions of operating system and applications; see order documents for equipment
Power consumption per PCIe slot with x4 expansion card, maximum permitted	<ul style="list-style-type: none"> 3.3 V / 3 A 12 V / 2.1 A 3.3 V_{aux} / 0.4 A
Power consumption per PCIe slot with x16 expansion cards, max. permissible	<ul style="list-style-type: none"> 3.3 V / 3 A 12 V / 2.1 A 3.3 V_{aux} / 0.4 A
Max. permitted power consumption per PCI slot (5V, 32-bit)	5V, 5A or 3.3 V, 7A; 12V 0.5A; 3.3 V _{aux} 0.4A
PCI modules with exclusive 5 V supply	≤ 25 W
Power loss per slot with max. ambient air temperature 40 °C, permissible	≤ 25 W
Power loss of all slots with max. ambient air temperature 40 °C, permissible	≤ 75 W In sum, the current for 3.3 V _{aux} may not exceed 1.2 A.

8.8 Technical specifications of graphic

See the note in "Applicability of technical specifications (Page 69)".

Graphic controller	Intel® HD Graphics, 3D engine (integrated in processor)
Graphics memory	Dynamic Video Memory Technology, uses 32 MB and 1.7 GB RAM in main memory
Resolutions/frequencies/colors	<ul style="list-style-type: none"> • DisplayPort up to 4096 × 2304 pixels at 60 Hz; color depth up to 32-bit/pixel • VGA (VGA via DP to VGA adapter) up to 1920 × 1200 pixels at 60 Hz; color depth up to 32 bits/pixel

8.9 Technical specifications of the interfaces

Observe the information in "Applicability of technical specifications (Page 69)" and use only original connections of the I/O to be connected.

COM	<p>On the rear panel:</p> <ul style="list-style-type: none"> • 2 × RS232/RS485/RS422 (9-pin header) <p>On the motherboard :</p> <ul style="list-style-type: none"> • 2 × RS232 (9-pin header)
DP	<p>Connection of a digital monitor</p> <ul style="list-style-type: none"> • 1 × DP <p>The maximum length of DP cable is less than 15 meters, and the DP cable must comply with VESA DisplayPort standard.</p>
VGA	<p>Connection of an analog monitor</p> <ul style="list-style-type: none"> • 1 × VGA
Keyboard	Connection through PS/2 or USB port
Mouse	Connection through PS/2 or USB port
USB	<p>On the rear panel:</p> <ul style="list-style-type: none"> • 4 × USB 3.0 (900 mA) <p>On the front panel:</p> <ul style="list-style-type: none"> • 2 × USB 2.0 (500 mA) <p>On the motherboard:</p> <ul style="list-style-type: none"> • 2 × USB 2.0 vertical (500 mA) • 2 × USB 2.0 (500 mA, 2-pin header)
Ethernet	<p>2 × Ethernet interface (RJ45, 10/100/1000 Mbps) Wake on LAN, remote boot supported.</p>
Audio	<p>Realtek® ALC887, 5.1 channels, high definition audio codec.</p> <ul style="list-style-type: none"> • Micro • Line In • Line Out

8.10 Technical specifications of the telescopic rails

Ultimate load per pair	≥ 30 kg
Full extraction length	≥ 470 mm
Rail thickness	≤ 9.7 mm
Mounting screws	M5 x 6 mm The mounting screws of the telescopic rails may not protrude by more than 5 mm into the enclosure.

8.11 Technical specifications of the operating systems

Depending on the ordered device configuration, the device is equipped with or **without** the following installed operating systems.

- Microsoft® Windows® 10 Enterprise 2019 LTSC, 64-bit, Multi-Language*

*Multi-Language User Interface (MUI): 6 languages (English, Chinese, German, French, Spanish, Italian)

You can find information on ordered Microsoft® Windows® operating systems under: Important instructions and manuals for operating the device (Page 8).

Boot mode and partitions in the delivery state

Delivery state for Windows® 10

In the delivery state, Windows® 10 boot in UEFI mode.

The following table lists the partitioning for data storage media ≥ 200 GB in GPT mode:

Partition	Name	Size	File system
First	Boot	260 MB	FAT32
Second	MSR	128 MB	None
Third	System	160 GB	NTFS, not compressed
Fourth	Data	Remainder	NTFS, not compressed

8.12 Directives and declarations

8.12.1 Electromagnetic compatibility, Industrial and Residential Areas

Electromagnetic compatibility

This product meets the requirements of EC Directive 2014/30/EU "Electromagnetic Compatibility".

The device is designed for the following areas of application corresponding to the CE marking:

Scope of application	Requirements for	
	Interference emission	Immunity to interference
Industrial area	EN 61000-6-4:2007 +A1:2011	EN 61000-6-2:2005

8.12.2 ESD guideline

What does ESD mean?

An electronic module is equipped with highly integrated components. Due to their design, electronic components are highly sensitive to overvoltage and thus to the discharge of static electricity. Such electronic components or modules are labeled as electrostatic sensitive devices.

The following abbreviations are commonly used for electrostatic sensitive devices:

- ESD – Electrostatic sensitive device
- ESD – Electrostatic Sensitive Device as a common international designation

Electrostatic sensitive devices can be labeled with an appropriate symbol.



NOTICE

Damage to ESD from touch

Electrostatic sensitive devices, ESD, can be destroyed by voltages which are far below the human perception limit. If you touch a component or electrical connections of a module without discharging any electrostatic energy, these voltages may arise.

The damage to a module by an overvoltage can often not be immediately detected and only becomes evident after an extended period of operation. The consequences are incalculable and range from unforeseeable malfunctions to a total failure of the machine or system.

Avoid touching components directly. Make sure that persons, the workstation and the packaging are properly grounded.

Charge

Every person without a conductive connection to the electrical potential of his/her surroundings can be electrostatically charged.

The material with which an electrostatically-charged person comes into contact is of particular significance. The figure shows the maximum electrostatic voltages with which a person is charged, depending on humidity and material. These values conform to the specifications of IEC 61000-4-2.

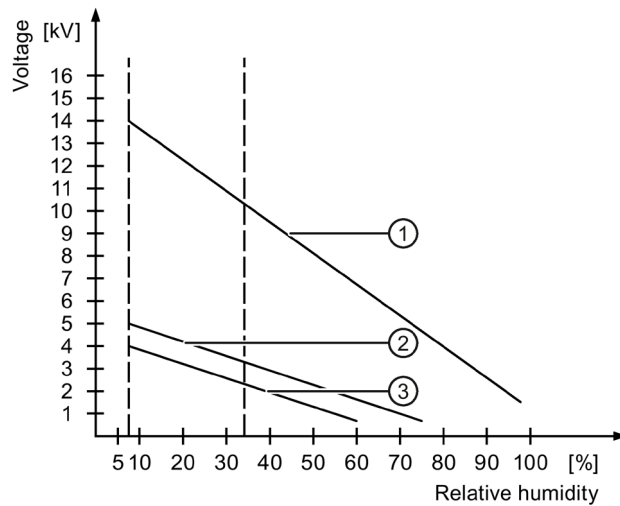

- ① Synthetic materials
- ② Wool
- ③ Antistatic materials such as wood or concrete

NOTICE

Grounding measures

There is no equipotential bonding without grounding. An electrostatic charge is not discharged and may damage the ESD.

Protect yourself against discharge of static electricity. When working with electrostatic sensitive devices, make sure that the person and the workplace are properly grounded.

Protective measures against discharge of static electricity

- Disconnect the power supply before you install or remove modules which are sensitive to ESD.
- Pay attention to good grounding:
When handling electrostatic sensitive devices, make sure that persons, the workstation and devices, tools and packaging used are properly grounded. This way you avoid static discharge.
- Avoid direct contact:
 - As a general rule, do not touch electrostatic sensitive devices, except in the case of unavoidable maintenance work.
 - Hold the modules at their edge so that you do not touch the connector pins or conductor paths. This way, the discharge energy does not reach and damage the sensitive components.
 - Discharge your body electrostatically by touching grounded metallic parts before you take a measurement at a module. Always use grounded measuring instruments.

Dimension drawings

Front view and top view

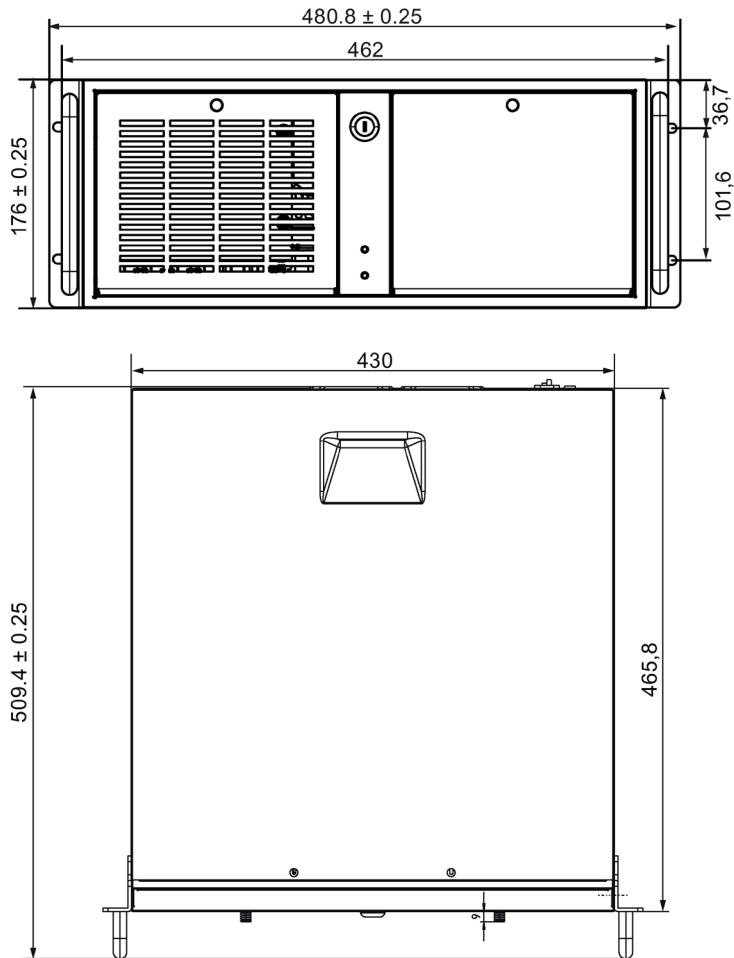

All dimensions in mm.

9.1 Dimension drawing of the expansion cards

Long PCI card, PCIe card

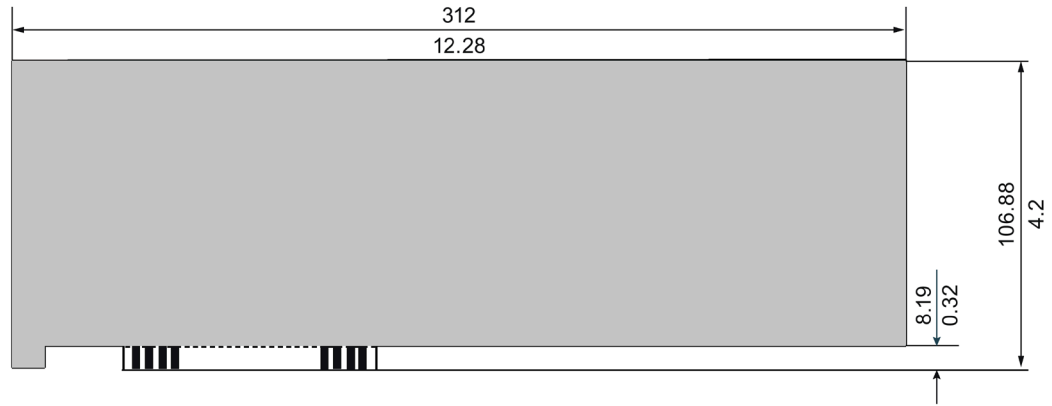

Dimension: mm / Inch

9.2 Dimension drawing of the telescope rails

Dimensions for bore holes for telescopic rails

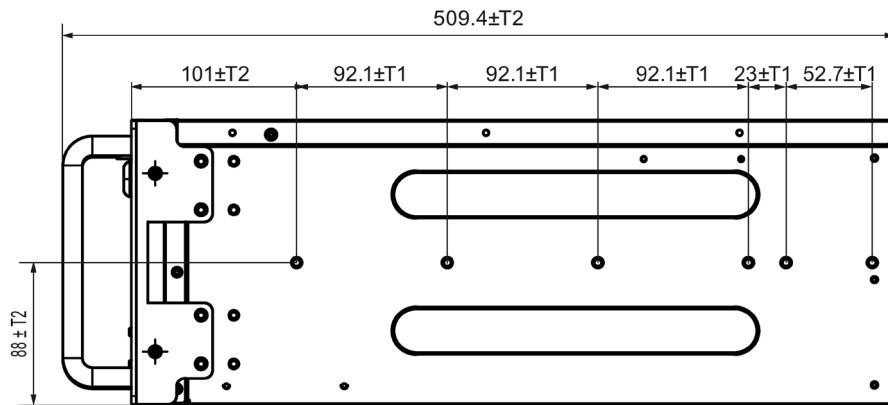

Dimensions: mm

T1=Tolerances of $\pm (0.1\text{mm})/(0.004\text{'})$

T2=Tolerances of $\pm (0.3\text{mm})/(0.01\text{'})$

Standards and approvals

Note

Applicability

The following shows the approvals that may be available. For the device itself, it is certificated as shown on the product label and package label.



2004/108/EC Directive of the European Parliament and of the Council of 15 December 2004 on the approximation of the laws of the Member States relating to electromagnetic compatibility (until 19.04.2016)

2014/30/EU Directive of the European Parliament and of the Council of 26 February 2014 on the harmonisation of the laws of the Member States relating to electromagnetic compatibility; Official Journal of the EU L96, 29/03/2014, p. 79–106 (from 20.04.2016)

Low Voltage Directive:

2006/95/EC Directive of the European Parliament and of the Council of 12 December 2006 on the harmonisation of the laws of Member States relating to electrical equipment designed for use within certain voltage limits (until 19.04.2016)

2014/35/EU Directive of the European Parliament and of the Council of 26 February 2014 on the harmonisation of the laws of the Member States relating to the making available on the market of electrical equipment designed for use within certain voltage limits; Official Journal of the EU L96, 29/03/2014, p. 357–374 (from 20.04.2016)

EMC	EN 61000-3-2:2006 + A1:2009 + A2:2009, EN 61000-3-3:2013, EN 61000-6-4:2007 + A1:2011, EN 61000-6-2:2005
LVD	EN 61010-2-201:2013; EN 61131-2:2007; EN 61010-1:2010

ISO 9001 certificate

The Siemens quality management system for all production processes (development, production and sales) meets the requirements of ISO 9001:2015, ISO 14001:2015 and ISO 45001:2018.

Certificate registration no. 01 100 1430201, 01 104 1430201 and 01 113 1430201.

Software license agreements

If the device is supplied with preinstalled software, you must observe the corresponding license agreements.

UL approval

The following approvals are available for the device:

- Underwriters Laboratories (UL) in accordance with Standard UL61010-1 and UL61010-2-201 (IND.CONT.EQ), File E472609
- Canadian National Standard CAN/CSA No.61010-1-12 and CAN/CSA C22.2 No.61010-2-201

FCC and Canada

USA	
Federal Communications Commission Radio Frequency Interference Statement	This equipment has been tested and found to comply with the limits for a Class A digital device, pursuant to Part 15 of the FCC Rules. These limits are designed to provide reasonable protection against harmful interference when the equipment is operated in a commercial environment. This equipment generates, uses, and can radiate radio frequency energy and, if not installed and used in accordance with the instruction manual, may cause harmful interference to radio communications. Operation of this equipment in a residential area is likely to cause harmful interference in which case the user will be required to correct the interference at his own expense.
Shielded Cables	Shielded cables must be used with this equipment to maintain compliance with FCC regulations.
Modifications	Changes or modifications not expressly approved by the manufacturer could void the user's authority to operate the equipment.
Conditions of Operations	This device complies with Part 15 of the FCC Rules. Operation is subject to the following two conditions: (1) this device may not cause harmful interference, and (2) this device must accept any interference received, including interference that may cause undesired operation.

CANADA	
Canadian Notice	This Class B digital apparatus complies with Canadian ICES-003.
Avis Canadien	Cet appareil numérique de la classe B est conforme à la norme NMB-003 du Canada.

Responsible party for Supplier's Declaration of Conformity

Siemens Industry, Inc.
 Digital Factory - Factory Automation
 5300 Triangle Parkway, Suite 100
 Norcross, GA 30092
 USA
 Mail to: (amps.automation@siemens.com)

AUSTRALIA / NEW ZEALAND

This product meets the requirements of the standard EN 61000-6-3 Generic standards - Emission standard for residential, commercial and light-industrial environments.

This product meets the requirements of the standard EN 61000-6-3 Generic standards - Emission standard for residential, commercial and light-industrial environments.

Identification for Eurasian Customs Union



- EAC (Eurasian Conformity)
- Customs union of Russia, Belarus and Kazakhstan
- Declaration of conformity according to Technical Regulations of the Customs Union (TR CU)

Korea Certificate



This product meets the requirements of Korean certification.

This product satisfies the requirement of the Korean Certification (KC Mark).

이 기기는 업무용(A 급) 전자파 적합기기로서 판매자 또는 사용자는 이 점을 주의하시기
바라며 가정 외의 지역에서 사용하는 것을 목적으로 합니다.

BIS



This product meets the requirements of India certification.

BSMI



This product meets the requirements of CNS14336-1(099/09/30), CNS13438(095/06/01)
generic standard.

警告使用者：本產品是甲類的資訊產品，在居家的環境中使用時，可能會造成射頻干擾，在
這類情況下，使用者會被要求採取某些適當的對策。

WEEE label (European Union)



Disposal instructions, observe the local regulations and the section "Recycling and disposal
(Page 68)".

BIOS description

11.1 BIOS getting started

BIOS setup utility: Aptio TSE

The BIOS is developed on AMI based code. AMI provides Aptio™ Text Setup Environment (TSE), a test-based basic input and output system as BIOS setup utility. The purpose of Aptio™ TSE is to empower the user with complete system control at boot.

Getting BIOS setup

To enter BIOS Setup at startup:

1. Power on the device.
2. Press **DELETE** or **ESC** key on your keyboard during the Power - On - Self - Test (POST) when the SIEMENS logo is shown on screen.

The Aptio™ TSE main BIOS setup menu is displayed.

You can access the other setup screens from the main BIOS setup menu, such as 'Advanced' menu.

Note

During the startup, if **DELETE** or **ESC** is not pressed, POST continues its routines.

If the timing is missed for entering BIOS setup during POST, a system reset is required by one of following methods:

- Press **CTRL + ALT + DELETE** simultaneously.
 - Press the power button to turn off system then turn it on.
-

BIOS setup menu

The Aptio™ TSE BIOS setup menu is the homepage of the BIOS setup. Each BIOS setup menu option is described in this manual.

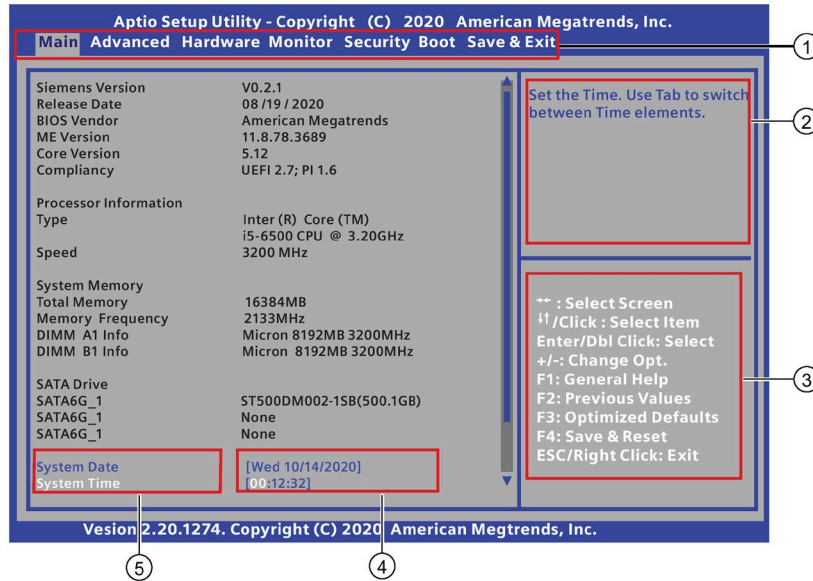

- ① Menu bar
- ② Function description fields
- ③ Navigation keys
- ④ Configuration fields
- ⑤ Menu items

Menu bar

The menu bar is on the top of the screen and has the following main items:

- Main: For changing the basic system configuration
- Advanced: For changing the advanced system settings.
- Hardware Monitor: For displaying the system temperature, power status, and changing the fan settings.
- Boot: For changing the system boot configuration.
- Security: For setting the administrator or user password, configure trusted devices or set secure boot.
- Save & Exit: For selecting the exit options and loading default settings.

Function description fields

Function description fields are at the top right corner of the menu screen and a brief description of the selected item.

Navigation key

The Aptio™ TSE keyboard-based navigation can be accomplished using a combination of the keys, for example, function keys, **Enter**, **ESC**, **ARROW** keys. Function description for navigation keys is listed below.

Press	To
→ ← : Select Screen	Menu Bar and select a BIOS setup page, for example, the Main menu.
↑ ↓/Click : Select Item	Select a BIOS setup item or sub page.
Enter/Dbf Click : Select	Select an option to edit its value or access a sub menu.
+ / - : Change Opt.	Change the field value of a particular setup item, for example, date, time.
F1 : General Help	Display the general help window.
F2: Previous Values	Enable user to load previous values in BIOS setup Menu.
F3: Optimized Defaults	Enable user to load optimized default values in BIOS Setup Menu.
F4: Save & Exit	Enable user to save the current configuration and exit BIOS Setup Menu.
ESC/Right Click: Exit	The <ESC> Key or Right Click allows you to discard any change have made and exit BIOS setup menu.

Configuration fields

Configuration fields show the values for the menu items. If an item is user-configurable, you can change the value of the field opposite the item. You cannot select an item that is not user configurable.

A configurable field is enclosed in brackets, and is highlighted when selected. To change the value of a field, select it and press **Enter** to display a list of options.

Menu items

Menu items are system parameters in each page and vary according to different menu pages.

11.2 Main menu

The Main menu

The Main menu provides you an overview of the basic system information, and allows you to set the system date and time.

Note

Take the BIOS version installed on your IPC as standard.

BIOS information

BIOS Information contains the following items:

Item	Description
Siemens Version	Show the BIOS release version information.
Release Date	Show the BIOS release date information.
BIOS Vendor	Show the BIOS vendor information.
ME Version	Show the ME version information.
Core Version	Show the core version information.
Compliance	Show the compliance information.

System Date

You can follow the steps to set the system date information.

1. Use arrow key to select the data.
2. Navigate to the month, day and year and type in the value as you need. Press **Enter** to jump to next field.
3. Press **F4** key and save the change.

System Time

You can follow the steps to set the system time.

1. Use arrow key to select the data.
2. Navigate to the hour, minute and second and type in the value as you need. Press **Enter** to jump to next field.
3. Press **F4** key and save the change.

Note

Enter the time in the 24-hour format. For example, you should enter 06:30:00 for 6:30 AM.

11.3 Advanced menu

Advanced menu

The **Advanced** menu allows you to change the settings for the CPU and other system devices.

Note

Be cautious when changing the settings of the Advanced menu. Incorrect field value can cause the system to malfunction.

CPU Configuration

In the CPU configuration page, you can check and configure the CPU-related information that the BIOS automatically detect.

System parameters	Function description	Configuration options	Default setting
Intel (VMX)Virtualization Technology	Enable or disable the intel virtualization technology. <ul style="list-style-type: none"> [Enabled]: A VMM can utilize the additional hardware capabilities provided by Vanderpool Technology. [Disabled]: Disable this function. 	<ul style="list-style-type: none"> [Enabled] [Disabled] 	[Enabled]
Turbo Mode	Enable or disable the processor Turbo Mode.	<ul style="list-style-type: none"> [Enabled] [Disabled] 	[Enabled]
Active Processor Cores	Select the number of CPU cores to activate in each processor package. Note: Some of the CPU types only have [All] and [1] options.	<ul style="list-style-type: none"> [All] [1] [2] [3] 	[All]
EIST	Enable or disable Enhanced Intel SpeedStep® Technology.	<ul style="list-style-type: none"> [Enabled] [Disabled] 	[Enabled]
Reserve for OS memory	Select the reserve value for operating system memory.	<ul style="list-style-type: none"> [Dynamic] [3 GB] 	[Dynamic]

Chipset Configuration

In the Chipset Configuration page, you can change the platform settings.

System parameters	Function description	Configuration options	Default setting
Primary Display ¹	Select the Primary Display from IGFX/PEG/PCI Graphics device or select SG for switchable Gfx.	<ul style="list-style-type: none"> [Auto] [CPU Graphics] [PCIe] 	[CPU Graphics]
iGPU Multi-Monitor	Enable or disable the iGPU Multi-Monitor. <ul style="list-style-type: none"> [Enabled]: To empower both integrated and discrete graphics. The iGPU shared system memory size will be fixed at 64MB. [Disabled]: Disable this function. 	<ul style="list-style-type: none"> [Enabled] [Disabled] 	[Disabled]
IGD Minimum Memory	Select DVMT 5.0 Pre_Allocated (Fixed) Graphics Memory size used by the Internal Graphics Device.	<ul style="list-style-type: none"> [32M] [64M] [96M] ~ [1024M] 	[128M]
Audio Controller	Enable or disable the Azalia HD audio controller.	<ul style="list-style-type: none"> [Enabled] [Disabled] 	[Enabled]

11.3 Advanced menu

System parameters	Function description	Configuration options	Default setting
Audio Detect	Enable or disable the audio device detection function.	<ul style="list-style-type: none"> [Enabled] [Disabled] 	[Enabled]
High Precision Timer	Enable or disable the High Precision Event Timer.	<ul style="list-style-type: none"> [Enabled] [Disabled] 	[Enabled]

¹ Refer to the following table to select the correct configuration options for Primary Display when you connect external graphic cards.

System parameters		BIOS			Power On process			Windows operating system		
iGPU Multi-Monitor	Primary Display	I-VGA	I-DP	PEG	I-VGA	I-DP	PEG	I-VGA	I-DP	PEG
[Enabled]	[Auto]	×	×	✓	×	×	✓	✓	✓	✓
	[CPU Graphics]	✓	✓	×	✓	✓	×	✓	✓	✓
	[PEG]	×	×	✓	×	×	✓	✓	✓	✓
[Disabled]	[Auto]	×	×	✓	×	×	✓	×	×	✓
	[CPU Graphics]	✓	✓	×	✓	✓	×	✓	✓	✓
	[PEG]	×	×	✓	×	×	✓	×	×	✓

SATA Configuration

When you enter the BIOS Setup, the BIOS automatically detects the presence of SATA devices. If no SATA device is installed to the corresponding SATA port, the SATA Port items show Empty.

System parameters	Function description	Configuration options	Default setting
SATA6G_1	Enable or disable the SATA port SATA6G_1.	<ul style="list-style-type: none"> [Enabled] [Disabled] 	[Enabled]
SATA6G_1 Hot Plug	Enable or disable the SATA6G_1 Hot Plug Support.	<ul style="list-style-type: none"> [Enabled] [Disabled] 	[Disabled]
SATA6G_2	Enable or disable the SATA ports SATA6G_2.	<ul style="list-style-type: none"> [Enabled] [Disabled] 	[Enabled]
SATA6G_2 Hot Plug	Enable or disable the SATA6G_2 Hot Plug Support.	<ul style="list-style-type: none"> [Enabled] [Disabled] 	[Disabled]
SATA6G_3	Enable or disable the SATA port SATA6G_3.	<ul style="list-style-type: none"> [Enabled] [Disabled] 	[Enabled]
SATA6G_3 Hot Plug	Enable or disable the SATA6G_3 Hot Plug Support.	<ul style="list-style-type: none"> [Enabled] [Disabled] 	[Disabled]

USB Configuration

In the USB Configuration page, you can change the USB related features.

System parameters	Function description	Configuration options	Default setting
USB Port Per-Port Control	Enable or disable the USB ports individually. <ul style="list-style-type: none"> • LAN1_U31G1_1 (x60) • LAN1_U31G1_2 (x61) • LAN2_U31G1_3 (x62) • LAN2_U31G1_4 (x63) • USB5~10 	<ul style="list-style-type: none"> • [Enabled] • [Disabled] 	[Enabled]
Legacy USB Support	Enable or disable the Legacy USB Support. <ul style="list-style-type: none"> • [Enabled]: Enables the support for USB devices on legacy operating systems (OS). • [Disabled]: The USB devices can be used only for EFI applications. • [Auto]: The system detects the presence of USB devices at startup. If detected, the USB controller legacy mode is enabled. If no USB device is detected, the legacy USB support is disabled. 	<ul style="list-style-type: none"> • [Enabled] • [Disabled] • [Auto] 	[Enabled]

ACPI Settings

In the ACPI Settings page, you can change the ACPI settings.

System parameters	Function description	Configuration options	Default setting
Restore AC Power Loss	Restore the AC power loss. <ul style="list-style-type: none"> • [Always On]: The system goes into on state after an AC power loss. • [Always Off]: The system goes into off state after an AC power loss. • [Last State]: The system goes into either off or on state, whatever the system state was before the AC power loss. 	<ul style="list-style-type: none"> • [Always On] • [Always Off] • [Last State] 	[Last State]
ErP Ready	Allow BIOS to switch off power at S5 state to get the system ready for ErP requirement.	<ul style="list-style-type: none"> • [Enabled] • [Disabled] 	[Disabled]
Resume from PCI	Enable or disable wake on function of PCI devices.	<ul style="list-style-type: none"> • [Enabled] • [Disabled] 	[Disabled]
Resume from PCI-E/LAN	Enable or disable the wake-on-LAN function of the onboard LAN controller or the PCIE LAN cards.	<ul style="list-style-type: none"> • [Enabled] • [Disabled] 	[Disabled]
Resume from S5 via PS2	Enable or disable resume from S5 state via PS2.	<ul style="list-style-type: none"> • [Enabled] • [Disabled] 	[Disabled]
Resume from S5 via USB	Enable or disable resume from S5 state via USB.	<ul style="list-style-type: none"> • [Enabled] • [Disabled] 	[Disabled]

Serial Port Configuration

In the Serial Port Configuration page, you can set the serial port configuration.

System parameters		Function description	Configuration options	Default setting
Serial Port 1 Configuration	Serial Port 1	Enable or disable the serial port (COM) 1.	<ul style="list-style-type: none"> [Enabled] [Disabled] 	[Enabled]
	Change Settings	When you set the Serial Port 1 to [Enabled], this item allows you to select the Serial Port base address.	<ul style="list-style-type: none"> [Auto] [IO=3F8h; IRQ=4] [IO=3F8h; IRQ=3, 4, 5, 6, 7, 9, 10, 11, 12;] [IO=2F8h; IRQ=3, 4, 5, 6, 7, 9, 10, 11, 12;] [IO=3E8h; IRQ=3, 4, 5, 6, 7, 9, 10, 11, 12;] [IO=2E8h; IRQ=3, 4, 5, 6, 7, 9, 10, 11, 12;] 	[Auto]
	COM1 Control	When you set the Serial Port 1 to [Enabled], this item allows you to select the COM1 mode.	<ul style="list-style-type: none"> [RS232] [RS422] [RS485] 	[RS232]
Serial Port 2 Configuration	Serial Port 2	Enable or disable the serial port (COM) 2.	<ul style="list-style-type: none"> [Enabled] [Disabled] 	[Enabled]
	Change Settings	When you set the Serial Port 2 to [Enabled], this item allows you to select the Serial Port base address.	<ul style="list-style-type: none"> [Auto] [IO=2F8h; IRQ=3] [IO=3F8h; IRQ=3, 4, 5, 6, 7, 9, 10, 11, 12;] [IO=2F8h; IRQ=3, 4, 5, 6, 7, 9, 10, 11, 12;] [IO=3E8h; IRQ=3, 4, 5, 6, 7, 9, 10, 11, 12;] [IO=2E8h; IRQ=3, 4, 5, 6, 7, 9, 10, 11, 12;] 	[Auto]
	COM2 Control	When you set the Serial Port 2 to [Enabled], this item allows you to select the COM2 mode.	<ul style="list-style-type: none"> [RS232] [RS422] [RS485] 	[RS232]

System parameters		Function description	Configuration options	Default setting
Serial Port 3 Configuration	Serial Port 3	Enable or disable the serial port (COM) 3.	<ul style="list-style-type: none"> [Enabled] [Disabled] 	[Enabled]
	Change Settings	When you set the Serial Port 3 to [Enabled], this item allows you to select the Serial Port base address.	<ul style="list-style-type: none"> [Auto] [IO=2F0h; IRQ=7] [IO=3E8h; IRQ=3, 4, 5, 6, 7, 9, 10, 11, 12;] [IO=2E8h; IRQ=3, 4, 5, 6, 7, 9, 10, 11, 12;] [IO=2F0h; IRQ=3, 4, 5, 6, 7, 9, 10, 11, 12;] [IO=2E0h; IRQ=3, 4, 5, 6, 7, 9, 10, 11, 12;] 	[Auto]
Serial Port 4 Configuration	Serial Port 4	Enable or disable the serial port (COM) 4.	<ul style="list-style-type: none"> [Enabled] [Disabled] 	[Enabled]
	Change Settings	When you set the Serial Port 4 to [Enabled] and allows you to select the Serial Port base address.	<ul style="list-style-type: none"> [Auto] [IO=2E0h; IRQ=7] [IO=3E8h; IRQ=3, 4, 5, 6, 7, 9, 10, 11, 12;] [IO=2E8h; IRQ=3, 4, 5, 6, 7, 9, 10, 11, 12;] [IO=2F0h; IRQ=3, 4, 5, 6, 7, 9, 10, 11, 12;] [IO=2E0h; IRQ=3, 4, 5, 6, 7, 9, 10, 11, 12;] 	[Auto]

M.2 Detect Information

This page displays the information of the connected M.2 devices.

Onboard Device Configuration

In the Onboard Device Configuration page, you can configure the onboard devices.

System parameters	Function description	Configuration options	Default setting
INTEL LAN1_X1P1 Controller	Enable or disable the INTEL LAN_X1P1 Controller.	<ul style="list-style-type: none"> [Enabled] [Disabled] 	[Enabled]
INTEL LAN1_X1P1 PXE OPROM	Enable or disable the INTEL LAN1_X1P1 PXE OPROM.	<ul style="list-style-type: none"> [Enabled] [Disabled] 	[Enabled]
INTEL LAN2_X2P1 Controller	Enable or disable the INTEL LAN2_X2P1 Controller.	<ul style="list-style-type: none"> [Enabled] [Disabled] 	[Enabled]

System parameters	Function description	Configuration options	Default setting
INTEL LAN2_X2P1 PXE OPROM	Enable or disable the INTEL LAN2_X2P1 PXE OPROM.	<ul style="list-style-type: none"> • [Enabled] • [Disabled] 	[Enabled]
Add-on PCIE LAN Card PXE Boot	Enable or disable the Add-on PCIE LAN Card PXE Boot.	<ul style="list-style-type: none"> • [Enabled] • [Disabled] 	[Disabled]
Charging USB device in Power State S5	Enable or disable the charging USB devices even when the system is in Power State S5.	<ul style="list-style-type: none"> • [Enabled] • [Disabled] 	[Enabled]

Network Stack Configuration

In the Network Stack Configuration page, you can configure network stack.

System parameters	Function description	Configuration options	Default setting
Network Stack	Enable or disable the UEFI Network Stack.	<ul style="list-style-type: none"> • [Enabled] • [Disabled] 	[Enabled]
Ipv4 PXE Support	Enable or disable the Ipv4 PXE Boot support.	<ul style="list-style-type: none"> • [Enabled] • [Disabled] 	[Enabled]
Ipv6 PXE Support	Enable or disable the Ipv6 PXE Boot support.	<ul style="list-style-type: none"> • [Enabled] • [Disabled] 	[Enabled]

PCIE Configuration

In the PCIE Configuration page, you can configure the onboard devices.

System parameters	Function description	Configuration options	Default setting
PCIEX16	Enable or disable the PCIEX16.	<ul style="list-style-type: none"> • [Enabled] • [Disabled] 	[Enabled]
PCIEX16 Speed	Configure PCIEX16 Gen1-Gen3.	<ul style="list-style-type: none"> • [Auto] • [Gen1] • [Gen2] • [Gen3] 	[Auto]
PCIEX16 Non-Compliance mode	Detect Non-Compliance PCI Express Device in PCIEX16.	<ul style="list-style-type: none"> • [Enabled] • [Disabled] 	[Disabled]
PCIEX4 Lane Configuration	Set the PCIEX4 Lane.	<ul style="list-style-type: none"> • 1x2 2x1 Port • 1x4 Port 	[1x2 2x1 Port]
PCIEX4_1	Enable or disable the PCIEX4_1.	<ul style="list-style-type: none"> • [Enabled] • [Disabled] 	[Enabled]

System parameters	Function description	Configuration options	Default setting
PCIEX4_1 Speed	Configure PCIEX4_1 Gen1-Gen2.	<ul style="list-style-type: none"> • [Auto] • [Gen1] • [Gen2] 	[Auto]
PCIEX4_1 Non-Compliance mode	Detect Non-Compliance PCI Express Device in PCIEX4_1.	<ul style="list-style-type: none"> • [Enabled] • [Disabled] 	[Disabled]
PCIEX4_2	Enable or disable the PCIEX4_2.	<ul style="list-style-type: none"> • [Enabled] • [Disabled] 	[Enabled]
PCIEX4_2 Speed	Configure PCIEX4_2 Gen1-Gen2.	<ul style="list-style-type: none"> • [Auto] • [Gen1] • [Gen2] 	[Auto]
PCIEX4_2 Non-Compliance mode	Detect Non-Compliance PCI Express Device in PCIEX4_2.	<ul style="list-style-type: none"> • [Enabled] • [Disabled] 	[Disabled]
PCIEX4_3	Enable or disable the PCIEX4_3.	<ul style="list-style-type: none"> • [Enabled] • [Disabled] 	[Enabled]
PCIEX4_3 Speed	Configure PCIEX4_3 Gen1-Gen2.	<ul style="list-style-type: none"> • [Auto] • [Gen1] • [Gen2] 	[Auto]
PCIEX4_3 Non-Compliance mode	Detect Non-Compliance PCI Express Device in PCIEX4_3.	<ul style="list-style-type: none"> • [Enabled] • [Disabled] 	[Disabled]

11.4 Hardware Monitor menu

Hardware Monitor menu

The Hardware Monitor menu displays the system temperature/power status, and allows you to change the fan settings.

System parameters	Function description	Configuration options	Default setting
CPU Temperature	The onboard hardware monitor automatically detects and displays the CPU temperatures.	None	None
Air inlet temperature	The onboard hardware monitor automatically detects and displays the air inlet temperature.	None	None
Air outlet temperature	The onboard hardware monitor automatically detects and displays the air outlet temperature.	None	None
CPU / CHA Fan Speed	The onboard hardware monitor automatically detects and displays the CPU / chassis fan speeds in rotations per minute (RPM).	None	None

System parameters	Function description	Configuration options	Default setting
CPU VCORE,+5V, +12V, +3.3VSB, +5VSB, VBAT	The onboard hardware monitor automatically detects the voltage output through the onboard voltage regulators.	None	None
CPU Fan Control	Control the CPU fan. <ul style="list-style-type: none"> [Auto Mode]: CPU Fan speed change based on CPU temperature. 	None	[Auto Mode]
CHA Fan1 Control	Control the chassis fan. <ul style="list-style-type: none"> [Auto Mode]: Chassis Fan speed change based on motherboard temperature. [Silent Mode]: Chassis Fan speed keep stable and no noise. [Disabled Mode]: Uses Maximum speed 	<ul style="list-style-type: none"> [Auto Mode] [Silent Mode] [Disabled Mode] 	[Silent Mode]
CHA Fan2 Control	Control the chassis fan. <ul style="list-style-type: none"> [Auto Mode]: chassis Fan speed change based on motherboard temperature. [Silent Mode]: chassis Fan speed keep stable and no noise. [Disabled Mode]: Uses Maximum speed 	<ul style="list-style-type: none"> [Auto Mode] [Silent Mode] [Disabled Mode] 	[Silent Mode]

11.5 Boot menu

Boot menu

The Boot menu allows you to change the system boot options.

Boot Configuration

In the Boot Configuration page, you can modify the boot up screen between POST message and SIEMENS logo.

System parameters	Function description	Configuration options	Default setting
Fast Boot	Change the boot speed. <ul style="list-style-type: none"> [Enabled]: Select to accelerate the boot speed. [Disabled]: Select to go back to normal boot. 	<ul style="list-style-type: none"> [Enabled] [Disabled] 	[Disabled]
Quiet Boot	Enable or disable the Quiet Boot option.	<ul style="list-style-type: none"> [Enabled] [Disabled] 	[Enabled]
HDD Boot	Enable or disable the HDD Boot option.	<ul style="list-style-type: none"> [Enabled] [Disabled] 	[Enabled]

System parameters		Function description	Configuration options	Default setting
USB Boot		Enable or disable the USB Boot option.	<ul style="list-style-type: none"> [Enabled] [Disabled] 	[Disabled]
PCIe NVME boot support		Enable or disable the PCIe NVME boot support.	<ul style="list-style-type: none"> [Enabled] [Disabled] 	[Enabled]
CSM (Compatibility Support Module)	Launch CSM	Launch the compatibility support module: <ul style="list-style-type: none"> [Enabled]: Support the non-UEFI driver add-on devices or the windows UEFI mode. [Disabled]: Support the Windows secure update and secure boot. 	<ul style="list-style-type: none"> [Enabled] [Disabled] 	[Enabled]
	Boot from Network Devices	Select the type of the onboard LAN controllers and installed LAN cards. Network devices run the selected type during the system boot. <ul style="list-style-type: none"> [UEFI only] [Legacy only] 	<ul style="list-style-type: none"> [UEFI only] [Legacy only] 	[Legacy only]
	Boot from Storage Devices	Storage devices will run the selected type first during the system boot. <ul style="list-style-type: none"> [UEFI only] [Legacy only] It is recommended to select either "Legacy only" or "UEFI only" by the devices specification for a better stability.	<ul style="list-style-type: none"> [UEFI only] [Legacy only] 	[Legacy only]
	Boot from PCI-E Expansion Devices	PCI-E Expansion devices will run the selected type first during the system boot. <ul style="list-style-type: none"> [UEFI only] [Legacy only] 	<ul style="list-style-type: none"> [UEFI only] [Legacy only] 	[Legacy only]
S5 RTC Wake Configuration	Wake up on Alarm	Select whether to enable Wake Up on Alarm, to turn on your system on a special day of the month, special day of the week or daily. Note: Values in these fields may be overwritten by the operating system.	<ul style="list-style-type: none"> [Disabled] [Single event] [Daily event] [Weekly event] [Monthly event] 	[Disabled]
Boot mode select		Select the devices boot-up mode according to the devices specification and different operating systems. Devices with the selected mode will appear in the boot priority list.	<ul style="list-style-type: none"> [Legacy] [UEFI] 	Windows 7 OS: [Legacy] Windows 10 OS: [UEFI]
Fixed BOOT order Priorities(UEFI mode)	Boot Option #1	Set the system boot order.	<ul style="list-style-type: none"> [UEFI Hard Disk] [UEFI USB Device] [UEFI Network] [UEFI CD/DVD] [Disabled] 	[UEFI Hard Disk]
	Boot Option #2			[UEFI USB Device]
	Boot Option #3			[UEFI Network]
	Boot Option #4			[UEFI CD/DVD]

System parameters		Function description	Configuration options	Default setting
Fixed BOOT order Priorities(Legacy mode)	Boot Option #1	Set the system boot order.	<ul style="list-style-type: none"> • [Hard Disk] • [USB Device] • [Network] • [CD/DVD] • [Disabled] 	[Hard Disk]
	Boot Option #2			[USB Device]
	Boot Option #3			[Network]
	Boot Option #4			[CD/DVD]

Boot Option Priorities

These items specify the boot device priority sequence from the available devices. The number of device items that appears on the screen depends on the number of devices installed in the system.

Note

- Select the boot device during system startup, and press <F10> when SIEMENS Logo appears.
- Access Windows OS in Safe Mode, press <F8> after POST.

11.6 Security menu

Security menu

NOTICE
<p>Risk of unauthorized modification for BIOS setting</p> <p>Everyone can access BIOS and change its setting if you don't set a password for BIOS. Modifying the BIOS setting arbitrarily may interfere with device function.</p> <p>Set passwords for administrator and user to avoid unauthorized access and modification to BIOS.</p>

Security menu provides both Administrator and User password. If you want use both of these two passwords, the Administrator password must be set firstly. The Administrator and User passwords activate two different levels of password security.

After the passwords are set, you must enter a password every time when you enter BIOS.

Select **Security** item in BIOS Setup screen to enter Security menu.

Administrator Password

This option allows you to set an administrator password level password for BIOS.

If you have set an administrator password, Siemens recommends that you enter the administrator password for accessing the BIOS.

To set an administrator password:

1. Select **Administrator Password** item with the arrow keys and press **Enter** key.
2. Enter a password (The password of at least three characters in length and can be up to 20 characters long and case-sensitive) in the **Create New Password** box, and then press **Enter**.
3. Enter your password again in the **Confirm New Password** box, and then click **OK**.

To change an administrator password:

1. Select **Administrator Password** item with the arrow keys and press **Enter** key.
2. Enter the current password in the **Enter Current Password** box, and then press **Enter**.
3. Enter a new password in the **Create New Password** box, and then press **Enter**.
4. Enter your password again in the **Confirm New Password** box, and then click **OK**.

User Password

User password is displayed if you have set the Administrator Password.

This option allows you to set a user level password for BIOS.

If you have set a user password, you must enter the user password for accessing the BIOS. The **User Password** item on top of the screen shows the default **Not Installed**. After you set a password, this item shows **Installed**.

To set a user password:

1. Select **User Password** with the arrow keys and press **Enter** key.
2. Enter a password (The password of at least three characters in length and can be up to 20 characters long and case-sensitive) in the **Create New Password** box, and then press **Enter**.
3. Enter your password again in the **Confirm New Password** box, and then click **OK**.

To change a user password:

1. Select **User Password** with the arrow keys and press **Enter** key.
2. Enter the current password in the **Enter Current Password** box, and then press **Enter**.
3. Enter a new password in the **Create New Password** box, and then press **Enter**.
4. Enter your password again in the **Confirm New Password** box, and then click **OK**.

To clear the user password:

Follow the same steps as in changing a user password, but click **OK** when prompted to create/confirm the password. After you clear the password, the **User Password** item on top of the screen shows **Not Installed**.

Note

Record the new password when the password is changed. If you forget the password, you can contact Siemens Technical support.

Trusted Computing

This option allows you to configure trusted devices:

System parameters	Function description	Configuration options	Default setting
Security Device Support	When you set the boot mode to UEFI in Boot menu, you can set this item to enable or disable BIOS support for security device.	<ul style="list-style-type: none"> [Enabled] [Disabled] 	[Enabled]
SHA-1 PCR Bank	Enable or disable SHA-1 PCR Bank.	<ul style="list-style-type: none"> [Enabled] [Disabled] 	[Enabled]
SHA256 PCR Bank	Enable or disable SHA256 PCR Bank.	<ul style="list-style-type: none"> [Enabled] [Disabled] 	[Enabled]
Pending Operation	Schedule an operation for the security device. Note: Your computer will reboot during restart in order to change state of security device.	<ul style="list-style-type: none"> [None] [TPM Clear] 	[None]
Platform Hierarchy	Enable or disable platform hierarchy.	<ul style="list-style-type: none"> [Enabled] [Disabled] 	[Enabled]
Storage Hierarchy	Enable or disable storage hierarchy.	<ul style="list-style-type: none"> [Enabled] [Disabled] 	[Enabled]
Endorsement Hierarchy	Enable or disable endorsement hierarchy.	<ul style="list-style-type: none"> [Enabled] [Disabled] 	[Enabled]
TPM2.0 UEFI Spec Version	Select the TCG2 Spec Version Support: TCG_1-2: the compatible mode for Win8/Win10. TCG_2: Support new TCG2 protocol and event format for Win10 or later.	<ul style="list-style-type: none"> [TCG_1-2] [TCG_2] 	[TCG_2]
Physical Presence Spec Version	Select the PPI Spec version 1.2 or 1.3.	<ul style="list-style-type: none"> [1.2] [1.3] 	[1.3]

Secure Boot

System parameters		Function description	Configuration options	Default setting
Secure Boot		Set the secure boot. Platform key (PK) is enrolled and the system is in user mode. The mode change requires platform reset.	<ul style="list-style-type: none"> [Enabled] [Disabled] 	[Disabled]
Secure Boot Mode		Select the Boot Mode: <ul style="list-style-type: none"> [Standard] [Custom]: In this mode, Secure Boot policy variables can be configured by a physically present user without full authentication. 	<ul style="list-style-type: none"> [Standard] [Custom] 	[Custom]
Key Management	Install Default Secure Boot Keys	Load the default secure boot keys.	None	None
	PK Management	Enroll Factory Defaults or load certificates from a file.		
	KEK Management			
	DB Management			
	DBX Management			

11.7 Save & Exit menu

Save & Exit menu

The **Save & Exit** menu allows you to load the optimal default values for the BIOS items, and save or discard your changes to the BIOS items.

System parameters	Function description
Save Changes and Reset	All changes are saved. After the system is rebooted, the new system configurations take effect.
Discard Changes and Reset	Reboot the system without saving the changes.
Restore Defaults	Restore/load default values for all setup options.
Save as User Defaults	This option saves current configuration as User Defaults.
Restore User Defaults	This option restores User Defaults to all setup options.
Enter EZ-Flash mode	Press Enter to launch EZ-Flash mode.
Save Setup Profile to File System Drive	Press Enter to save setup profile to file system drive.
Load Setup Profile from File System Drive	Press Enter to load setup profile from file system drive.

Hardware description

A.1 Motherboard

A.1.1 Layout of the motherboard

The motherboard consists of these main components: processor and chipset, six slots for PCIe modules, two slots for memory modules, internal and external interfaces, Flash BIOS and the backup battery.

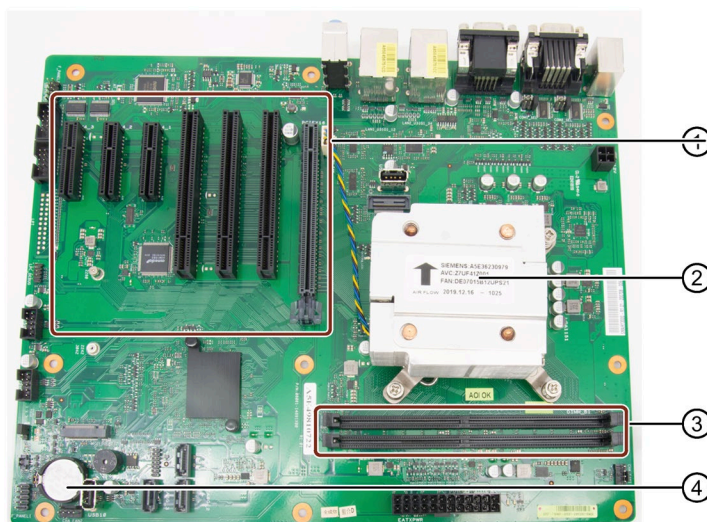

- ① Slots for PCIe/PCI modules
- ② CPU Fan and processor
- ③ Slots for memory modules
- ④ Backup battery

Technical features of the motherboard

Technical features of the motherboard can be found under "Technical specifications of the motherboard (Page 73)".

A.1.2 Position of the interfaces on the motherboard

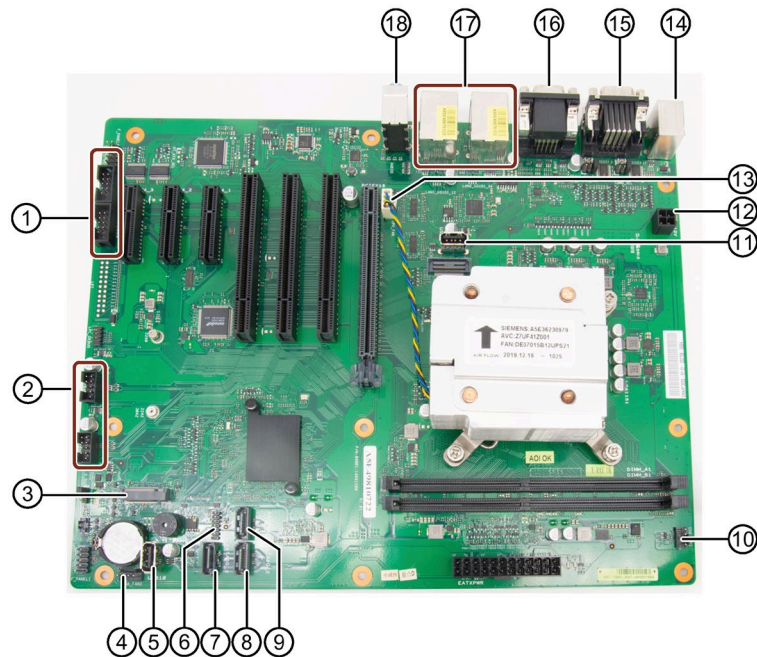

- | | |
|----------------------------------|-------------------------------------|
| ① COM4 pin header
COM3 header | ⑩ Chassis Fan 1 pin header |
| ② USB 2.0 pin header | ⑪ USB 2.0 vertical port |
| ③ M.2 2242/2280 B Key slot | ⑫ CPU Power |
| ④ Chassis Fan 2 pin header | ⑬ CPU Fan pin header |
| ⑤ USB 2.0 vertical port | ⑭ PS2 |
| ⑥ TPM pin header | ⑮ COM1
COM2 |
| ⑦ SATA 3 (Port 3) | ⑯ VGA
DPP |
| ⑧ SATA 2 (Port 2) | ⑰ LAN
USB 3.0 |
| ⑨ SATA 1 (Port 1) | ⑱ Microphone
Line OUT
Line IN |

A.1.3 Jumpers

 **WARNING**

Electrostatic sensitive devices (ESD)

The motherboard contains electronic components which can be destroyed by electrostatic charges. This can result it in malfunctions and damage to the machine or plant.

Always completely disconnect to the power cord from your motherboard when you are working on it. Do not make connections while the power is on, because a sudden rush of power can damage the sensitive electronic components.

Always ground yourself to remove any static charge before touching the board. Modern electronic devices are very sensitive to static electric charges. Use a grounding wrist strap at all times. Place all electronic components on a static-dissipative surface or in a static-shielded bag when they are not in the chassis.

 **WARNING**

Improper operations on the motherboard may result in substantial damage to the motherboard or endanger the operator

- Do not remove or ruin the motherboard serial number labels. These labels and the serial numbers are required for warranty validation.
- Wear electrostatic discharge (ESD) wrist strap or gloves when handling or touching the motherboard.
- When handling the motherboard, avoid to touch any metal leads or connectors.
- Always unplug the AC power cord from the power outlet before you installing or removing the motherboard.
- Place the motherboard on an anti-static pad or in a electrostatic shielding container during the operation.
- Turn off the power supply before you removing the power supply cable from the motherboard.
- Before turning on the power supply, check if the input voltage setting follows the local voltage standard.
- Before operating the motherboard, make sure that the cables and the power connectors of all the attached hardware components are connected. Turning on the power before you connect them, the motherboard and the system components may get damaged and injure operator.
- Make sure you securely attached the hardware components to the motherboard connectors/ slots/ sockets.
- The screws are not allowed to connect with motherboard circuit or components. The motherboard can be damaged by this action.
- Do not leave the screws or the metal components on the motherboard or inside of the chassis.

Setting Jumpers

The board has a number of jumpers that allow you to configure your system to suit your application. A jumper is a kind of electric switch. Through setting jumpers, you can configure your card to match the needs of your application.

A jumper consists of two metal pins and a small metal clip (often protected by a plastic cover). To connect the pins, lid the pin with the clip. To disconnect a jumper, remove the clip.

A pair of needle nose pliers may be helpful when working with jumpers. If you have any doubts about the best hardware configuration for you application, contact your local distributor or sales representative before you make any change.

Clear CMOS (CLRTC)

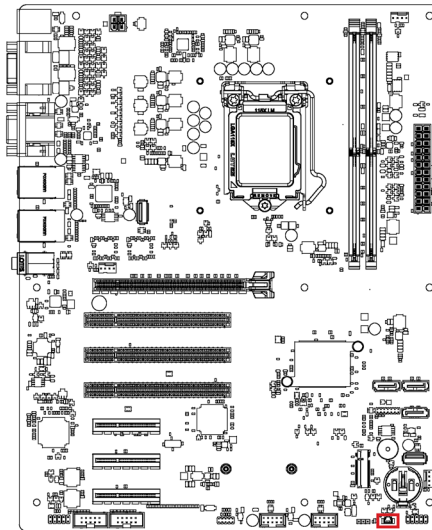

CLRTC

Jumper position	Function
Connect 1 and 2	Clear CMOS
Disconnect 1 and 2	Protected (Default)



Clear CMOS

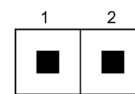

Protected
(Default)

NOTICE

Set the jumper back to protected mode after clearing CMOS.

COM +5V/+12V Selection (COM1_SEL/COM2_SEL)

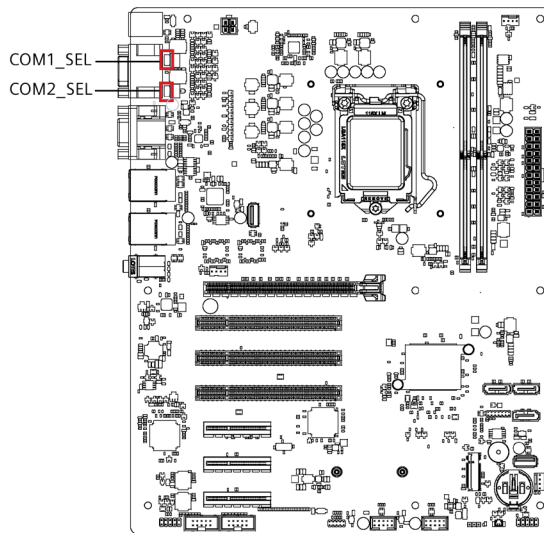

COM1_SEL / COM2_SEL	
Jumper position	Function
1-2	+12V/250mA
3-4	+5V/250mA
5-6	Ring(Default)

+12V: Jumper between pins 2 and 1.
 +5V: Jumper between pins 4 and 3.
 Ring(Default): Jumper between pins 6 and 5.

A.2 External interfaces

Note

Interface specification

The data of all external interfaces listed below correspond to the respective interface specifications and the intended use.

Interface	Connector	Description	Assignment
COM	COM1, COM2	9-pin standard plug	
USB 3.0 Type A	LAN1_U31G1_12, LAN2_U31G1_34	USB3 Port 0, 1; USB2 Port 0, 1 interface side	
Ethernet 1 and 2	LAN1_U31G1_12, LAN2_U31G1_34	RJ45	
DPP	DP	20-pin DisplayPort connector	

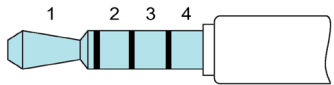
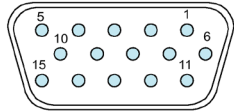
Audio	AUDIO	4-pin 3.5 mm UAJ jack	
VGA	VGA	Connection of an analog monitor	

A.2.1 USB 3.0 port

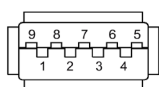

Pin	Short name	Meaning	Input / output
1	VBUS	+ 5 V (fused)	Output
2	D-	Data channel USB2	Input / output
3	D+	Data channel USB2	Input / output
4	GND	Ground	–
5	RX-	Data channel USB3	Input
6	RX+	Data channel USB3	Input
7	GND	Ground	–
8	TX-	Data channel USB3	Output
9	TX+	Data channel USB3	Output

A.2.2 USB 2.0 port

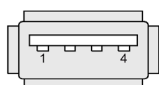

Pin	Short description	Meaning
1	USB_P5V_fused (O)	+5 V, fused
2	USB_D0M (I/O)	Data–
3	USB_D0P (I/O)	Data+
4	USB_GND	GND

A.2.3 Serial interface

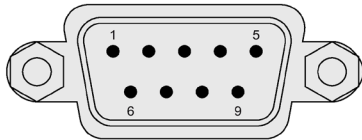

RS232
RS422
RS485

Pin assignment RS232

Pin	Short description	Meaning
1	DCD	Data carrier detect (I)
2	RxD	Received data (I)
3	TxD	Transmitted data (O)
4	DTR	Data terminal ready (O)
5	M	Ground
6	DSR	Data set ready (I)
7	RTS	Request to send (O)
8	CTS	Clear to send (I)
9	RI	Incoming call (I)

Pin assignment RS422

Pin	Short description	Meaning
1	TX-	Transmit data - (O) for full-duplex mode
2	TX+	Transmit data + (O) for full-duplex mode
3	RX+	Receive data + (I) for full-duplex mode
4	RX-	Receive data - (I) for full-duplex mode
5	M	Signal ground
6	nc	
7	nc	
8	nc	
9	nc	

Pin assignment RS485

Pin	Short description	Meaning
1	Data-	Transmit / receive data - (I/O) for half-duplex mode
2	Data+	Transmit / receive data+ (I/O) for half-duplex mode
3	nc	
4	nc	
5	M	Signal ground
6	nc	
7	nc	
8	nc	
9	nc	

A.2.4 Ethernet

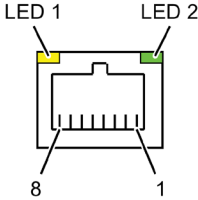
Ethernet RJ45 interface			
			
Pin no.	Short description	Meaning	Input / output
1	BI_DA+	Bi-directional data A+	Input/output
2	BI_DA-	Bi-directional data A-	Input/output
3	BI_DB+	Bi-directional data B+	Input/output
4	BI_DC+	Bi-directional data C+	Input/output
5	BI_DC-	Bi-directional data C-	Input/output
6	BI_DB-	Bi-directional data B-	Input/output
7	BI_DD+	Bi-directional data D+	Input/output
8	BI_DD-	Bi-directional data D-	Input/output
S		Shield	-
	LED 1	OFF: <ul style="list-style-type: none"> No cable connected Physical link disconnects Interface disabled Yellow: Active connected Yellow flashing: Data transfer active	-
	LED 2	Off: 10 Mbps Orange: 100 Mbps Green: 1000 Mbps	-

The Ethernet interface supports MDXI (auto crossover) for all transmission rates.

A.2.5 DisplayPort

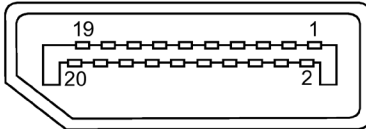
DisplayPort interface			
			
Pin no.	Abbreviation	Meaning	Input/output
1	ML_Lane3-	DP data 3-	Input
2	GND	Ground	-
3	ML_Lane3+	DP data 3+	Input
4	ML_Lane2-	DP data 2-	Input

DisplayPort interface			
5	GND	Ground	-
6	ML_Lane2+	DP data 2+	Input
7	ML_Lane1-	DP data 1-	Input
8	GND	Ground	-
9	ML_Lane1+	DP data 1+	Input
10	ML_Lane0-	DP data 0-	Input
11	GND	Ground	-
12	ML_Lane0+	DP data 0+	Input
13	CONFIG1	CONFIG1	-
14	CONFIG2	CONFIG2	-
15	AUX_CH+	Auxiliary channel+	Bidirectional
16	GND	Ground	-
17	AUX_CH-	Auxiliary channel-	Bidirectional
18	HPD	Hot Plug Detect	output
19	GND	Ground	-
20	DP_PWR	+3.3 V (fused)	power out

A.3 Internal Connector

A.3.1 Fan connector

The pin assignment in the table below applies to all fan connectors on motherboard.

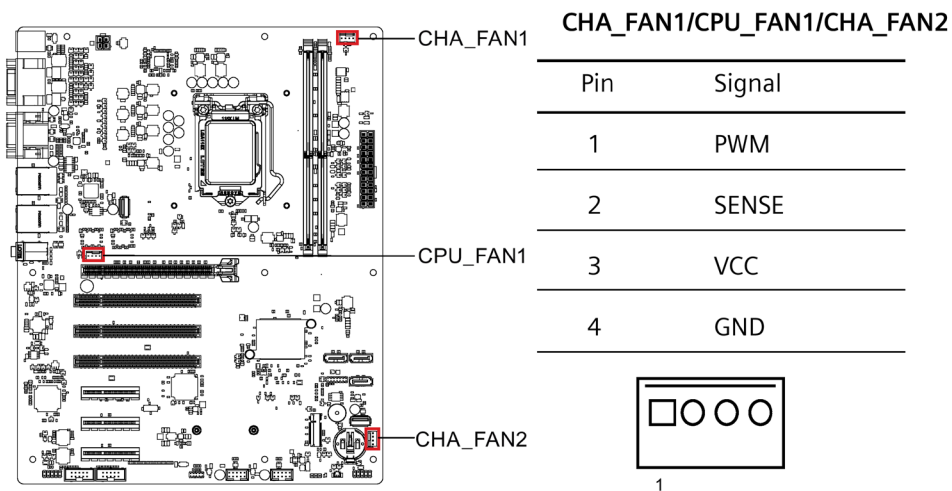

A.3.2 Front panel connector (F_Panel1 & F_Panel2)

The front panel connector is used to connect cable to Chassis Front Panel, and provide HDD LED, Power LED, Power Button and Reset Button functions.

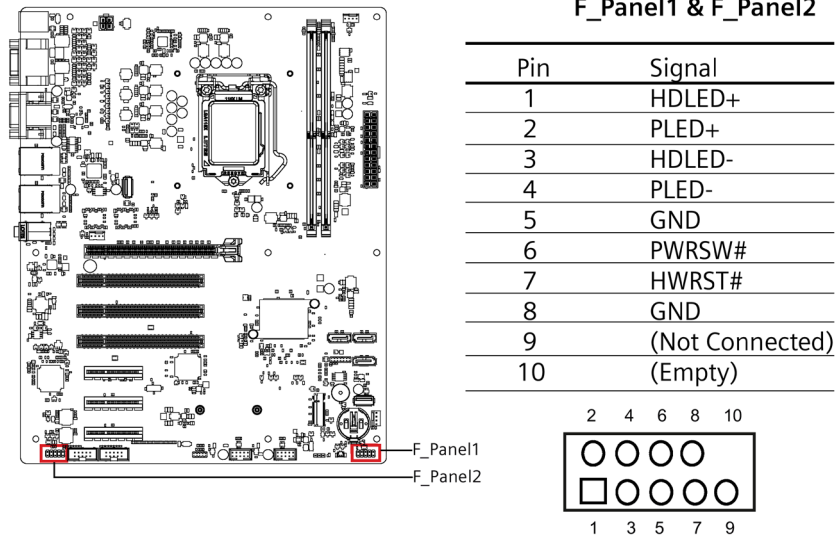

A.3.3 Internal USB 2.0 connector (USB56 & USB78)

Internal USB 2.0 Connectors provides two USB 2.0 Ports which require appropriate cable to support.

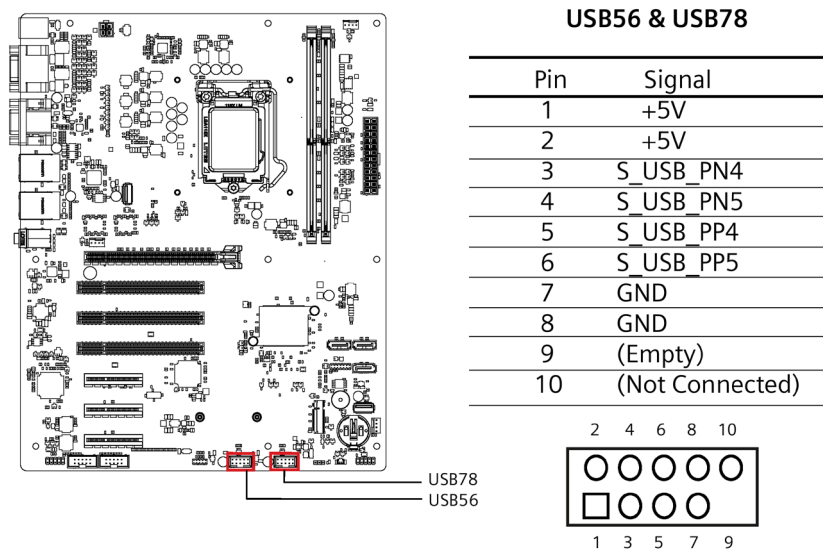

A.3.4 Internal RS232 COM Connector (COM3 & COM4)

Internal COM Connectors provides two RS232 Ports which require appropriate cable to support.

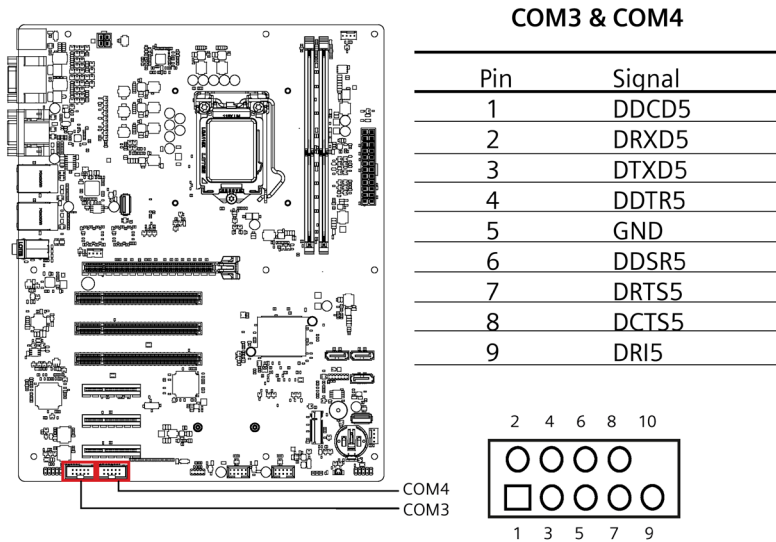

A.3.5 Internal USB 2.0 Vertical Connector (USB9 & USB10)

Internal USB 2.0 Vertical Connectors provides two Type-A USB 2.0 Ports.

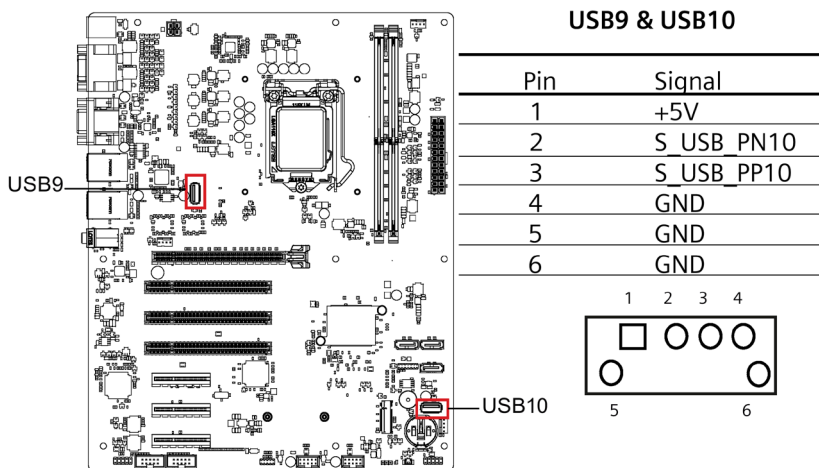

A.3.6 Internal TPM 14-pin connector

This socket allows you to install a TPM module.

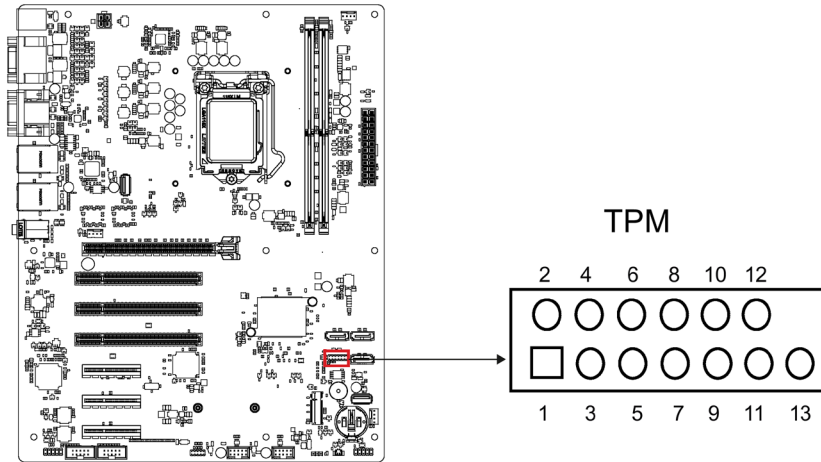

A.3.7 ATX power 24-pin connector (EATX_PWR1)

ATX Power 24-Pin connector is for ATX PSU plug. Make sure you insert the ATX PSU plug on motherboard in the right orientation, otherwise the plug cannot be inserted.

Note

ATX Power 4-Pin connector must be connected, otherwise the system cannot be turned on.

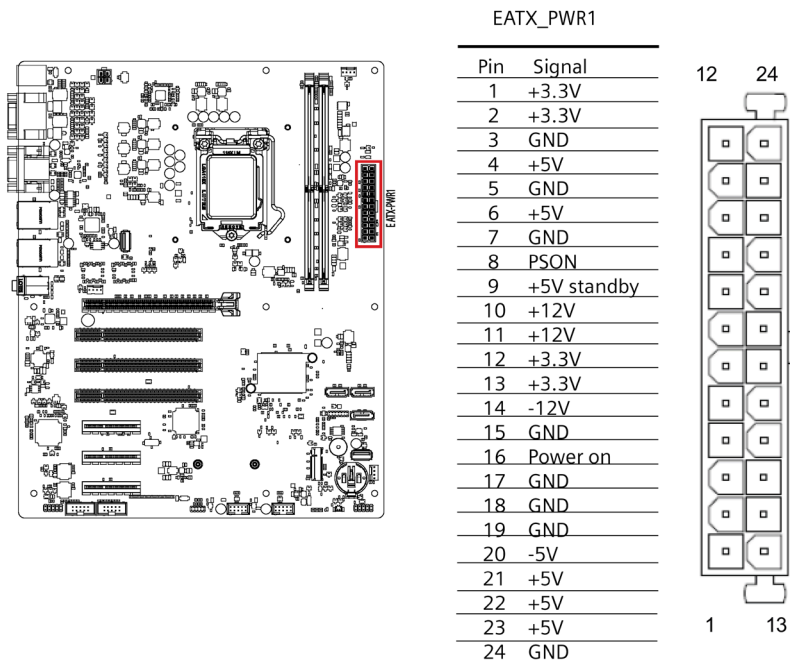

A.3.8 ATX Power 4-pin connector (EATX_PWR2)

ATX Power 4-Pin Connector is for ATX PSU plug. Make sure you insert the ATX PSU plug on motherboard in the right orientation, otherwise the plug cannot be inserted.

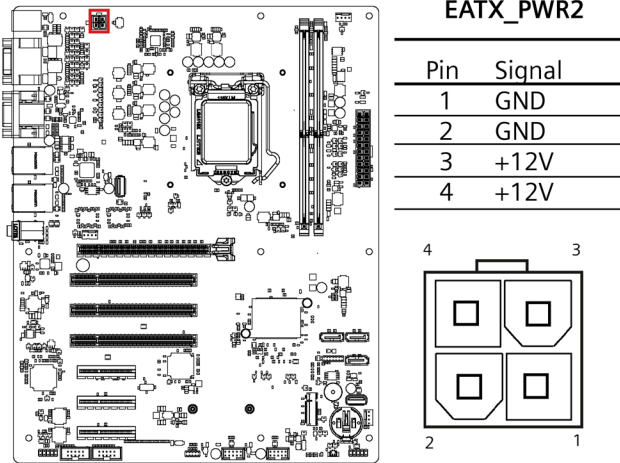

A.3.9 M.2 B Key slot

This socket allows you to install an M.2 module.

Note

This slot only supports type 2242/2280 SATA storage devices.

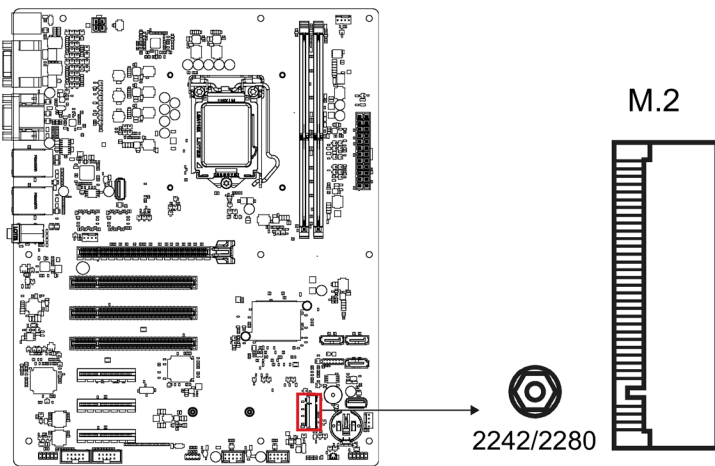

A.3.10 Intel CPU socket (LGA1151)

Intel CPU Socket is for Intel 1155 Pin CPU. Refer to the CPU installing section Replacing the processor (Page 62) for detailed information.

A.3.11 DDR4 Memory sockets (DIMM_A1 & DIMM_B1)

The motherboard provides two memory sockets, which support two pieces of 288-pin DDR4 Memory Modules. Refer to the chapter Installing memory module (Page 49) for detailed installation instruction.

A.3.12 SATA 6.0 Gbps Port Connectors (SATA6G_1/ SATA6G_2/ SATA6G_3)

The motherboard provides four pieces of 7-pin SATA Port Connectors, which support SATA devices through the connection of SATA Cable.

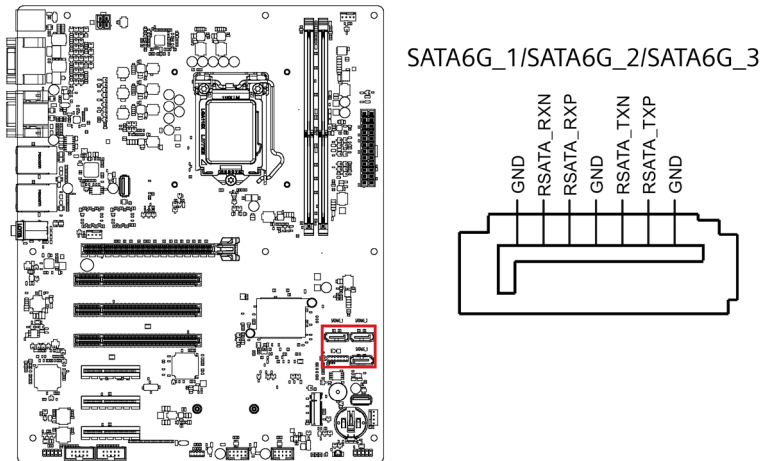

A.3.13 Battery socket

The Battery Socket on the motherboard is for CR2032 Battery used for COMS data retention.

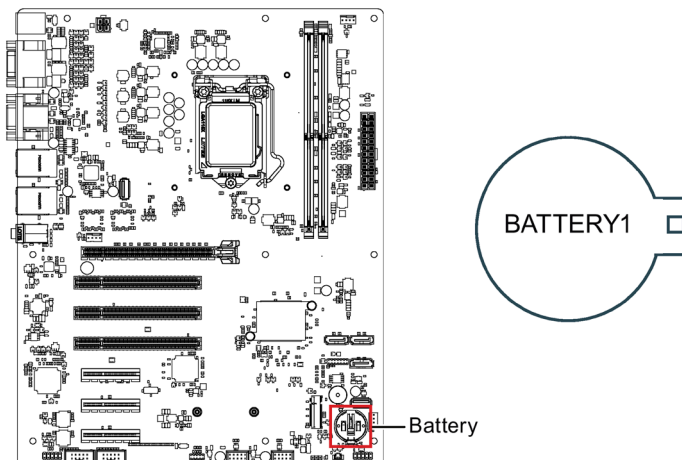

Technical support

B.1 Service and support

You can find additional information and support for the products described on the Internet at the following addresses:

- Technical support
(<https://support.industry.siemens.com/cs/start?lc=en-WW>)
- Support request form
(<https://support.industry.siemens.com/My/ww/en/requests#createRequest>)
- After Sales Information System SIMATIC IPC/PG
(<http://www.siemens.com/asis>)
- SIMATIC Documentation Collection
(<http://www.siemens.com/simatic-tech-doku-portal>)
- Your local representative
(http://w3.siemens.com/aspa_app/)
- Training center
(<https://www.sitrain-learning.siemens.com/PLG/?AppLang=en>)
- Industry Mall
(<https://mall.industry.siemens.com>)

When contacting your local representative or Technical Support, please have the following information at hand:

- Article number of the device (MLFB)
- BIOS version for industrial PC or image version of the device
- Other installed hardware
- Other installed software

Tools & downloads

Please check regularly if updates and hotfixes are available for download to your device. The download area is available on the Internet at the following link:

After Sales Information System SIMATIC IPC/PG (<http://www.siemens.com/asis>)

B.2 Troubleshooting

B.2.1 Problems with device functions

Problem	Cause	Remedy
The device is not operational	No power supply	<ul style="list-style-type: none"> Check the power supply, the power cable and the power plug. Check to see if the on-off switch is in the correct position.
	Device is being operated outside the specified ambient conditions	<ul style="list-style-type: none"> Check the ambient conditions. After transport in cold weather do not turn the power on until after a waiting period of approximately 12 hours.
The monitor remains dark	The monitor is switched off	Switch on the monitor.
	The monitor is in "power save" mode	Press any key on the keyboard.
	The brightness button has been set to dark	Increase brightness using the brightness button. Detailed information can be found in the operating manual for the monitor.
	The power cord or the monitor cable is not connected.	<ul style="list-style-type: none"> Check if the power cord is properly connected to the monitor and to the system unit or to the grounded shockproof power outlet. Check to make sure the monitor cable is properly connected to the system unit and the monitor. <p>Contact your technical support team if the screen still remains dark after all these controls and measures.</p>
The mouse pointer does not appear on the screen	The mouse driver is not loaded	Check whether the mouse driver is properly installed and available when you start the user program. Detailed information about the mouse driver is available in the corresponding documentation.
	Mouse not connected	<ul style="list-style-type: none"> Check to make sure that the mouse cable is properly connected to the system unit. If you use an adapter or extension cable for the mouse cable make sure to check these connections as well. <p>Contact your technical support team if the mouse pointer still does not appear on the screen after these controls and measures.</p>
Time and/or date of the PC is not correct		<ol style="list-style-type: none"> Open the firmware configuration menu. To do this, press the <ESC> key or <Delete> key during the boot operation. Set the date and the time in the "Main" tab.
Time and date are wrong even after correctly setting them in the firmware (BIOS)	The backup battery is dead.	Replace the backup battery.

Problem	Cause	Remedy
USB device not responding	USB ports are deactivated in the firmware (BIOS)	Use a different USB port or activate the port.
	Operating system does not support XHCI	Activate the firmware setting "PS/2 Emulation" in the firmware (BIOS) under "Advanced > USB Configuration".
	USB-2.0/3.0 device connected although USB-2.0/3.0 is deactivated	Activate the USB.
	Operating system does not support the USB interfaces	<ul style="list-style-type: none"> Activate the firmware setting "Legacy USB Support" in the firmware (BIOS) under "Advanced > USB Configuration". For other devices, you need the USB device drivers for the required operating system.
"chkdsk" is not functioning	EFW (Enhanced Write Filter) has been activated. The "chkdsk" command is not supported if the EFW has been activated.	Deactivate the EFW or use an alternative method to "chkdsk".

B.2.2 Problems when booting the device

Problem	Cause	Remedy
After changing the hard disk, "None" is indicated for the relevant SATA port.	System is booted without functioning drive.	Reboot the system with a functioning hard disk.
Computer does not boot or "Boot device not found" is displayed.	The boot medium is not approved	Set the boot priority to "Enabled" in the firmware (BIOS) under "Boot > Boot device".
	The boot device is not in first place of the boot priority in the BIOS setup	Change the boot priority in the firmware (BIOS) under "Boot > Boot device".
	The boot data storage medium is set up with GPT, and UEFI boot is deactivated in the firmware (BIOS)	Activate UEFI mode in the firmware (BIOS).
The startup of a Windows operating system located on a GPT data storage medium is aborted with the following error message: "Status: 0xc0000225 Info: The boot selection failed because a required device is inaccessible"	The settings in the boot loader file "BCD" are incorrect or damaged.	Restore the Windows® operating system. You can find the files and descriptions needed for this on the supplied data storage medium.

B.2.3 Problems when using expansion cards

Problem	Cause	Remedy
The device crashes during startup	<ul style="list-style-type: none"> • Redundant I/O addresses • Redundant hardware interrupts and/or DMA channels • Signal frequencies or signal levels are not adhered to • Different pin assignment 	<p>Check your computer configuration:</p> <ul style="list-style-type: none"> • If the computer configuration corresponds to the delivery state, contact your technical support team. • In the case of a change in the configuration, restore the delivery state. To do this, remove the expansion card and restart the device. If the error no longer occurs, the expansion card was the cause of the fault. Replace this with a Siemens expansion card or contact the supplier of the expansion card.
		If the device still crashes, contact your technical support team.
	Insufficient output of an external power supply, e.g. UPS	Use a powerful power supply.
The device does not start up or switches off immediately	A counter voltage is fed into the device by connected or installed expansion cards	<p>Clarify the following with the supplier of the component:</p> <ul style="list-style-type: none"> • The component can be operated without an external power supply. • The component can be reconfigured so that it only uses the external power supply or that of the device.









Markings and symbols

C.1 Overview



The following tables show all the symbols which may be found on your SIMATIC industrial PC, SIMATIC industrial monitor or SIMATIC Field PG in addition to the symbols which are explained in the operating instructions.

The symbols on your device may vary in some details from the symbols shown in the following tables.

C.2 Safety



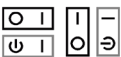







Symbol	Meaning		Symbol	Meaning
	Warning, observe the supplied documentation.			Lock is closed
	Attention, radio equipment			Lock is open
	Disconnect the power plug before opening			Opening for Kensington lock
	Attention ESD (Electrostatic sensitive device)			Warning of hot surface

C.3 Operator controls

Symbol	Meaning		Symbol	Meaning
	On/off switch, without electrical isolation			Eject CD/DVD
	On/off switch, without electrical isolation			

C.4 Certificates, approvals and markings

The following table shows symbols relating to certificates, approvals and markings which may be on the device. You can find more information in the operating instructions for your device:

Symbol	Meaning	Symbol	Meaning
	Approved for Australia and New Zealand RCM Certification		Marking for the Eurasian Customs Union
	Approved for China CCC Certification		Test mark of Factory Mutual Research
	CE markings for European countries		Marking of Federal Communications Commission for the USA
	EFUP (Environment Friendly Use Period) marking for China		Approved for Korea Certification (KC)
	Test mark of the Underwriters Laboratories		Disposal information, observe the local regulations.
 www.bis.gov.in	Approval for India BIS Certification		

C.5 Interfaces

Symbol	Meaning	Symbol	Meaning
	Connection to the power supply		PS/2 mouse interface
	Protective conductor terminal		PS/2 keyboard-interface
	Connection for functional earthing (equipotential bonding line)		Multimedia Card Reader
			Smart Card Reader
DPP	DisplayPort interface		Line In
	DVI-D interface		Line Out
LAN	LAN interface, not approved for connecting WAN or telephone		Microphone input
	Serial port		Headphone output
	USB port		USB 3.1 SuperSpeedPlus interface
	USB 2.0 high-speed port		
	USB 3.0 super-speed port		

List of abbreviations

Abbreviation	Term	Meaning
AC	Alternating current	Alternating current
AHCI	Advanced Host Controller Interface	Standardized controller interface for SATA devices. This is supported in Microsoft Windows XP as of SP1 and IAA driver.
APIC	Advanced Programmable Interrupt Controller	Extended programmable interrupt controller
AWG	American Wire Gauge	US standard for the cable diameter
CE	Communauté Européenne (CE symbol)	The product is in conformance with all applicable EC directives
CLK	Clock pulse	Clock signal for controllers
CMOS	Complementary Metal Oxide Semiconductors	Complementary metal oxide semiconductors
COA	Certificate of authentication	Microsoft Windows Product Key
COM	Communications Port	Term for the serial interface
CP	Communication Processor	Communication computer
CPU	Central Processing Unit	CPU
CSA	Canadian Standards Association	Canadian organization for tests and certifications according to own or bi-national standards (with UL / USA) standards
DC	Direct Current	DC current
DRAM	Dynamic Random Access Memory	
DMA	Direct Memory Access	Direct memory access
DOS	Disk Operating System	Operating system without GUI
DPP	DisplayPort	New powerful digital monitor port
DQS	Deutsche Gesellschaft zur Zertifizierung von Qualitätsmanagement mBH	
DVI / DVI-D	Digital Visual Interface	Digital display interface without VGA signals
DVI-I	Digital Visual Interface	Digital display interface with digital and VGA signals
ECP	Extended capability port	Extended parallel port
EFI	Extensible Firmware Interface	
ESD	Components sensitive to electrostatic charge	
EN	European standard	
HDD	Hard Disk Drive	Hard disk drive
HU	Height unit	
I/O	Input/Output	Data input/output on computers
iAMT	Intel® Active Management Technology	
IEC	International Electrotechnical Commission	
IP	Ingress Protection	Degree of protection

Abbreviation	Term	Meaning
IRQ	Interrupt Request	Interrupt request
LPT	Line Printer	Printer port
mDPP	mini DisplayPort	Digital monitor interface
MUI	Multilanguage User Interface	Language localization in Windows
NEMA	National Electrical Manufacturers Association	Syndicate of manufacturers of electrical components in the USA
NTFS	New Technology File System	Secure file system for Windows versions (2000, XP, 7)
OPC	OLE for Process Control	Standardized interface for industrial processes
PCI	Peripheral Component Interconnect	High-speed expansion bus
PCIe	Peripheral Component Interconnect express	High-speed serial, differential full-duplex PtP interface with high data rate.
PFC	Power Factor Correction	Harmonic suppression for operation on public networks.
PIC	Programmable Interrupt Controller	Programmable interrupt controller
PXE	Preboot Execution Environment	Software for running new PCs without hard disk data via the network
RAID	Redundant Array of Independent Disks	Redundant drive array
SATA	Serial Advanced Technology Attachment	
SDRAM	Synchronous DRAM	
SMART	Self Monitoring Analysis and Reporting Technology	Hard disk error diagnostics program
SJT	Service [Grade] Junior (Hard Service) Thermoplastic	PVC armored cable
SNMP	Simple Network Management Protocol	Network protocol
SSD	Solid State Drive	
TPM	Trusted Platform Module	
UEFI	Unified Extensible Firmware Interface	
UL	Underwriters Laboratories Inc.	US organization for tests and certifications according to own or binational standards (with CSA / Canada) standards.
USB	Universal Serial Bus	
V.24		ITU-T standardized recommendation for data transfer via serial ports
VCC		Positive supply voltage of integrated circuits
VEST	Video Electronics Standards Association	
VGA	Video Graphics Array	Video adapter which meets industrial standard
WD	Watchdog	Program monitoring with error detection and alarming.

Index

{

{"Canada"}{"FCC"}, 81

A

Ambient and environmental conditions, 24

Angle brackets

Mounting holes, 33

Approval, (EAC)

Approvals, 24

Audio devices

Connecting, 37

Australia, 81

B

Backup battery, 59

Maintenance interval, 55

BSMI, 82

C

Canada, 81

Certificates

Certifications and approvals, 80

Change drive

in mounting kit for 5.25" slot, 51

chkdsk, 116

Clock frequency, 64

COA label, 30

COM, 74

Components sensitive to electrostatic charge, 76

Condensation, 22

Connecting

function earth, 35

Network, 38

Connecting the function earth, 35

Connections, (Interfaces)

Country-specific information, 34

D

Data exchange, 38

Degree of protection, 69

Device fan, 56

Maintenance interval, 55

Removing and installing, 56

Dimension drawings, 78

Directive

ESD Directive, 76

DisplayPort interface, 107

Documentation, 8

Drive

install internally on the side panel of the device, 54

Drive bay plate, 54

Drive cage

Installation options for drives, 51

Numbering of the mounting locations, 13

Drives

Maintenance interval, 55

E

EAC, 82

Electrostatic sensitive devices, 21

Enclosure, 23

ESD, 76

ESD Directive, 76

Ethernet, 38

Ethernet interface, 107

Expansion

Hard Disk, 50

Expansion cards

Mounting, 46

usable expansion cards, 46

F

Fan, (Device fan), 57

FCC, 81

Filter pad

Maintenance interval, 55

Front door

Opening, 42

function earth, 35

Connecting, 35

G

General technical specifications, 69

Graphic controller, 74

Graphics memory, 74

H

Hard Disk Drives

Installation in drive cage, 51

Hardware reset, 41

Headphones

Connecting, 37

Headset

Connecting, 37

High frequency radiation

Immunity to interference, 25

I

I/O devices

Connecting, 37

Safety instructions, 25

Identification data, 29

Immunity to interference, 25

Initial commissioning, 39

Interface

DisplayPort, 107

Interfaces

On the device rear, 14

RJ45 Ethernet, 107

USB, 74

USB 2.0, 105

USB 3.0, 105

IT communication, 38

K

Korea Certificate, 82

L

LEDs, (Status displays)

Limitation of liability, 27

Lithium battery, 58

M

Main memory, 73

Manuals, 8

Memory modules

Installing, 49

Slots on motherboard, 73

Microphone

Connecting, 37

Module bracket, 48

Modules, 46

Motherboard

Changing, 64

Mounting

horizontally on device base, 32

with angle brackets, 32

with telescopic rails, 32

Mounting holes, 33

N

New Zealand, 81

O

On/Off button, 16

On/Off switch, 15

Open

Device, 45

Open the device, 45

Operating system

Initial commissioning, 39

Installed on delivery, 28, 75

Shutdown, 40

Output voltage

power supply, 71

P

Packaging

Checking, 29

PCI cards, 46

Pile au lithium, 59

Power requirements, 70

Power supply

Connecting the power supply, 36

Processor, 73

Changing, 62

Configuration, 62

Processor type, 64

Product label and component label, 30

PROFINET, 38

Protection class, 69

Protective measure

Static electricity, 77

R

- RAID, 116
- Removal
 - Device fan, 56

S

- Safety instructions
 - Ambient and environmental conditions, 24
 - Device and system extensions, 26
 - General, 19
 - I/O devices, 25
 - Mounting, 23
 - Transportation and storage, 22
- Scope of delivery, 28
 - Checking, 29
- SIMATIC NET, 38
- SIMATIC S7, 38, 38
 - Integration, 38
- Single power supply (AC)
 - Changing, 60
- Slot cover, 47
- Static electricity
 - Protective measures, 77
- Status displays
 - for the system, 17
- Storage, 22
- Switching off
 - Disconnecting the device from the line voltage, 40
 - Forced shutdown, (Hardware reset)
 - Hardware reset, 41
 - Shutting down the operating system, 40
- Switching on
 - Switching on the device, 39

T

- Telescopic rails
 - Mounting holes, 33
 - Technical specifications (basic configuration), 75
- Transportation, 22

U

- USB 2.0
 - Port, 105
- USB 3.0
 - Interface, 105

V

- Vent slots, 31
- vibration-damped drive cage, 13

